

Data Sheet

Analogue
Watt and Var Meters
240 ° Scale

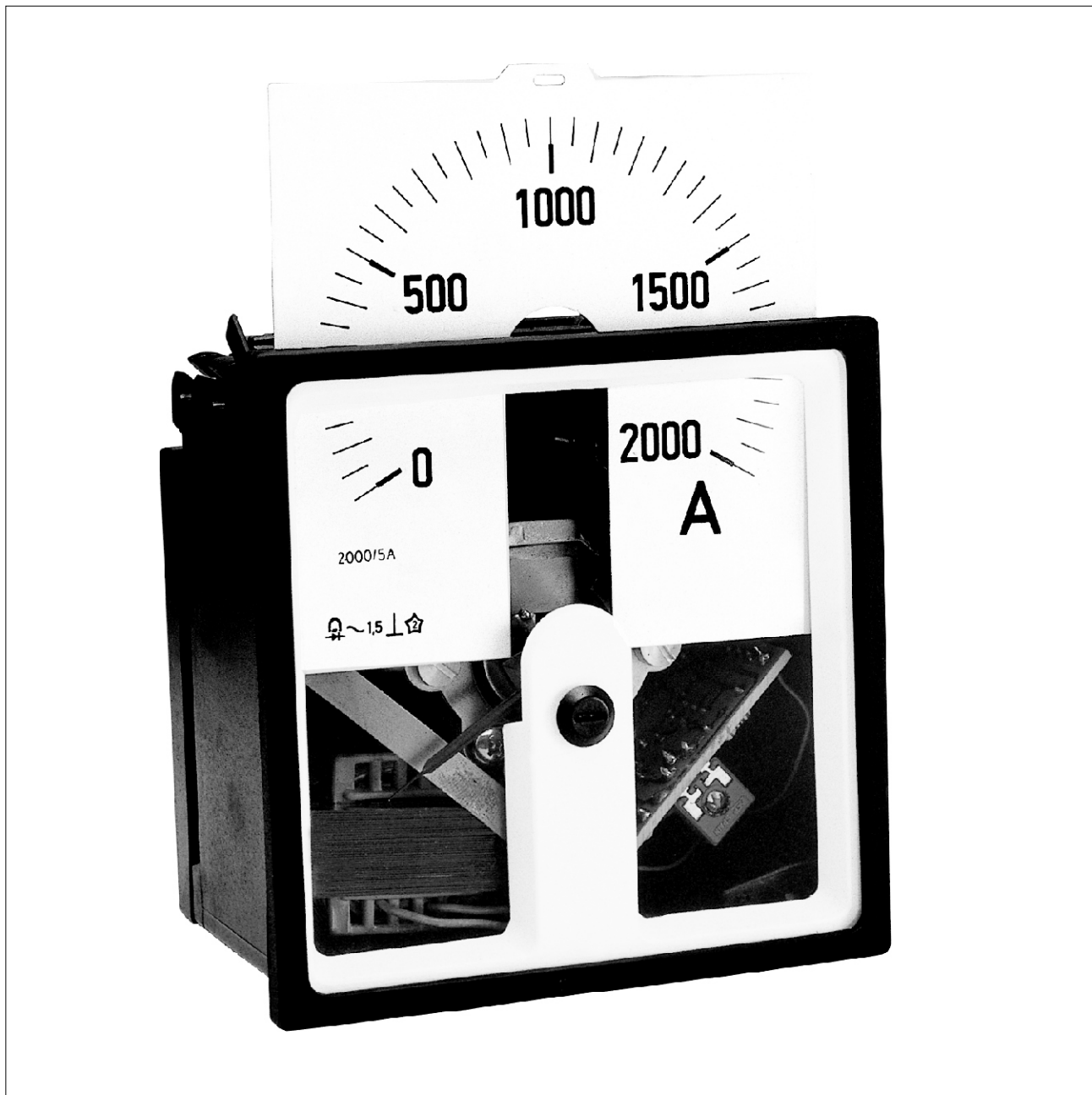

In Technical Collaboration with

Ziegler

GOSSEN
METRAWATT
CAMILLE BAUER

Application

The Watt and Var meters, WL 96 are offered for the following AC systems

- single phase
- 3 phase balanced load 3 or 4 wire
- 3 phase unbalanced load 3 or 4 wire

These instruments are suitable to indicate forward (export/out going) and reverse (import/in coming) power flow as well as inductive and capacitive reactive power. They can be used both on sinusoidal and non-sinusoidal current

These meters offer several advantages in Switchboard and Generating Set panels. Number of meters can be mounted in a single Cut out (Mosaic Mounting). The Bezel, Front window glass and Dial can be easily replaced

Functional Principle

For active and reactive power measurement, a moving-coil indicator is used to indicate watts and vars for which an analogue DC signal is obtained from a power converter attached to the case of the indicator.

Schematic diagram.

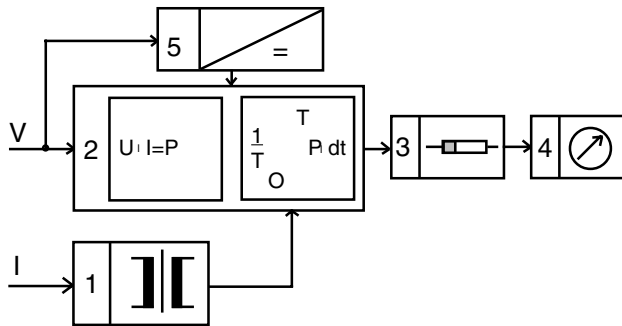

The power converter uses one, two or three multiplier systems depending on the measurement of balanced or unbalanced load AC systems. Current transformers 1 provide the input current to the multiplier circuit.

The multipliers form the product of the instantaneous values of current and voltage (TDM principle). Subsequently, the product resultant is integrated, thereby suppressing the AC ripple. Subsequently product proportional output is delivered to 3. There the voltage is converted into Current, whose magnitude also depends on Feasibility Factor (II). Finally this current is fed to the moving coil movement, 4. For the instrument DC power supply is obtained from input voltage, 5.

Mechanical Data

Case details	Moulded square case suitable for mounting in Control / Switchgear panels, Machinery consoles.
Case material	Glass filled polycarbonate, flame retardant and drip proof as per UL 94 V-0.
Front facia	Glass
Colour of bezel	Black
Position of use	Vertical
Panel fixing	Swivel screws.
Mounting	Stackable in a single cutout
Panel thickness	≤ 40 mm
Terminals	Hexagon studs, M4 screws and wire clamps E3

Electrical Data

Measured quantity	Active or Reactive Power
Response time	4s max.
Overload capacity (acc to IS : 1248/ IEC 51/ DIN EN 60051)	
Continuously	1.2 times rated voltage / current
Short duration	2 times rated voltage , 5 Sec max 10 times rated current , 5 Sec max
Power consumption (Approx):-	
Current path	≤ 0.2 VA
Voltage path types	
E1W, D1W, D1B, V1W, V1B	≤ 3.0 VA
E1B	≤ 3.5 VA
D2W, D2B	≤ 3.4 VA
V3W	≤ 3.9 VA
V3B	≤ 4.3 VA
Enclosures code	IP 52 case
(IEC 529)	IP 00 for terminals
Insulation class	Group A according to VDE 0110
Rated insulation voltage	660 V
Proof voltage testing	2 kV
Installation category	300 VCAT III
(IEC 1010)	
Insulation resistance	> 50 Mohm at 500 V d.c.

Standard Measuring Ranges

Type	Active power	Reactive power
Single phase system	E1W	E1B
3 phase 3 wire system balanced load	D1W	D1B
3 phase 4 wire system balanced load	V1W	V1B
3 phase 3 wire system unbalanced load	D2W	D2B
3 phase 4 wire system unbalanced load	V3W	V3B

selection of measuring range

Apparent power P_s is calculated from primary ratings of current transformer and voltage transformer.

In single phase network, $P_s = V \cdot I$

where V = voltage between phase and neutral & I = line current.

In three phase network, $P_s = \sqrt{3} \cdot V \cdot I$

where V = Voltage between two phases & I = line current.

Full scale value i.e range of the instrument (P_w = active power, P_b = reactive power) must be selected in such a way that the same remain between 0.5 times and 1.2 times the value of apparent power P_s .

Thus feasibility factor "Lambda" should be between 0.5 and 1.2 where "Lambda" = P_w/P_s or P_b/P_s

Full scale values shall preferably be selected from standard series according to DIN 43701, 1-1.2-1.5-2-2.5-3-4-5-6-7.5-8 and their decadic/decimal multiples.

Rated voltage:-

For Single phase (E1W, E1B) :- 57.7, 63.5, 100, 110, 127, 220, 289, 380.

For Three phase (D1W, D1B, D2W, D2B, V1W, V1B, V3W, V3B) :- 100, 110, 220, 240, 380, 415, 440, 500.

The voltage will be considered as a phase voltage (between phase and neutral) in case of single phase meters and as a line voltage (between two phases) in case of multiphase (2 wire, 3 wire and 4 wire) meters.

Rated current:-

1 A or 5 A

If used on current transformer, please state transformer ratio on the order.

Scale and Pointer

Pointer	Kinfe-edge pointer
Pointer deflection	0 ... 240 °
Scale characteristics	Linear
Scale division	Coarse-fine
Scale length	142 mm

Ziegler

Accuracy at Reference Conditions

Accuracy class	1.5 according to IS:1248 (IEC 51/ DIN EN 60051)
Reference conditions	
Ambient temperature	23° C ± 2° C
Position of use	Nominal position ± 1°
Input	Full-scale power value Pw or Pb
Feasibility factor	"Lambda"=Pw/Ps or Pb / Ps
Power factor	Cos Ø = 1 ± 0.01 for Watt meters & Sin Ø = 1 ± 0.01 for Var meters
Voltage	Rated voltage ± 2%
Frequency	45-65 Hz (50 Hz ± 0.1% for E1B)
Current	20% to 120% of rated current
Others	IS: 1248 (IEC 51/ DIN EN 60051)
Electrical and mechanical zero point in the meter are not necessarily identical. Zero adjustment should be done when only voltage is applied and current circuit not energised.	
Nominal range of use	
Ambient temperature	0 ... 50 ° C
Position of use	Nominal position ± 5°
External magnetic field	0.5 mT
Voltage	Rated voltage ± 15%
Power factor	CosØ = 1 to 0.5 (ind.) for active power Sin Ø = 1 to 0.5 (ind.) for reactive power
Frequency	45-65 Hz (50 Hz ± 1% for E1B)

Environmental Conditions

Climatic suitability	Climate category II as per IS : 1248 (climatic class 3 according to VDE / VDI 3540)
Operating temperature	-10 ... + 55 ° C
Storage temperature	-25 + 65 ° C
Relative humidity	≤ 75% annual average, non-condensing
Shock resistance	15g, 11ms
Vibration resistance	10-150-10 Hz/0.15 mm 1.5 g at about 50 Hz.

Applicable Standards

Nominal case and cutout dimensions for indicating electrical instruments.	: IS 2419 DIN 43700
Scale and pointer for electrical measuring instruments.	: IS 1248 - 1983 DIN 43802
Connections and Terminal markings for panel meters.	: IS 1248-1983 DIN 43807
Terminal bolts / leads	: DIN 46200/46282
Clamp straps for connections.	: DIN 46282
Safety requirements and protective measures for Electrical indicating instruments and their accessories.	: IS 9249-1979 DIN 40050 / 8-70 VDE 0110 /11-72 VDE 0410 /10-76 IEC 529,IEC 1010
Performance specifications for direct acting indicating analogue electrical measuring instruments and their accessories	: IS 1248-1983 IEC 51/DIN EN 60051 DIN 43701
Front frames for indicating measuring instruments principle dimensions.	: DIN 43718
Technical conditions of delivery for electrical instruments.	: DIN 43701
UL Combustibility class.	: UL 94 V-O
Mechanical strength (Free fall test, vibration test)	: IS 1248-1983,IEC 51 IS 9000-1979 VDE 0411, part I, Sec.43/44.IEC 1010

Data Sheet

Analogue Watt and Var Meters, 240 ° Scale

Environmental conditions : IS: 1248-1983
IS: 9000, Part 5,7,8
VDE / VDI 3540

Electro Magnetic Compatibility(EMC)Compliance as per following standards:- EN 50081-2,EN 50082-2,EN 55011/CISPR 11,
EN 60555-2,IEC 555-2,
EN 61000-4-4 / IEC 1000-4-4,
EN 61000-4-2 / IEC 1000-4-2,
EN 61000-4-5 / IEC 1000-4-5, ENV 50140.

Comply with following European directives: 89/336/EEC(EMC directive),73/23/EEC(low voltage directive)&amendment 93/68/EEC, for (CE) marking.

Options

Case	
Front facia	Antiglare glass
Colour of bezel	Red, Yellow, Blue, White
Red index pointer	Front adjustable on site
Position of use	on request 0 ° 180 °
Dial	
Blank dial	With initial and end values marked.
Special markings	Numbering /Lettering.
Division dials	Basic divisions without numbering.
Colour markings/bands	Red or green.

Dimensions

Dimensions (in mm)	WL 96
Bezel	a p 96
Case	b p 90
Depth	c 106 (E1W, E1B, D1W, D1B, V1W, V1B, D2W, D2B) (V3W, V3B)
	d 131
	e p 91.5
	e 5.5
Cutout	p 92 ^{+0.8}
Weight(Approx)	0.73 to 0.98Kg

Ziegler

Connections

Active Power

E1W-Single phase
(One element)

D1W -Three phase, three-wire
AC Supply with balanced load
(One element)

V1W -Three phase, four-wire
AC Supply with balanced load
(One element)

D2W -Three phase, three-wire
AC Supply with unbalanced load
(Two element)

V3W -Three phase, four-wire
AC Supply with unbalanced load
(Three element)

Reactive Power

E1B-Single phase
(One element)

D1B -Three phase, three-wire
AC Supply with balanced load
(One element)

V1B -Three phase, four-wire
AC Supply with balanced load
(One element)

D2B -Three phase, three-wire
AC Supply with unbalanced load
(Two element)

V3B -Three phase, four-wire
AC Supply with unbalanced load
(Three element)

Ordering Information

Type WL	Watt and Var meter, 240 ° Scale
Front dimension 96	96 mm x 96 mm
Type E1W, E1B D1W, D1B 3 phase V1W, V1B D2W, D2B V3W, V3B	Single phase systems 3 phase 3 wire system balance load 3 phase 4 wire system balance load 3 phase 3 wire system unbalance load 3 phase 4 wire system unbalance load
Measuring ranges	Specify while ordering
Rated voltages	Refer to table inside
Rated currents	1 A , 5 A
Front facia	Normal glass ¹ Antiglare glass ³
Colour of bezel	Black ¹ Red, Blue, Yellow, White ³
Position of use	Vertical ¹ On request 0 180 ° ³
Dial	Standard scale same as measuring range ¹ Blank dial with division ³ Additional lettering on request ³ Additional numbering on request ³ Coloured marking red or green ³ Coloured sector red or green ³
Logo	RISHABH ¹ , for Indian sales C.G. ¹ , export through Crompton Greaves I.D. Others ³

¹ standard

³ Please clearly add the desired specifications while ordering

Ordering example

WL 96 D V3W for active power 3 phase 4 wire system unbalanced load, measuring range 0 ... 480 kW, voltage AC 440 V, for use on current transformer 600/5A.

Safety Precautions

- * Instruments with damaged bezels or window glasses must be disconnected from mains.
- * Adequate safety clearance must be maintained to control panel fasteners and to sheet metal housing, if non- insulated connector wires are used.
- * Scales should be replaced under Voltage- free conditions.
- * Bezels and window glasses should be replaced under Voltage - free conditions

Specifications are subject to change without notice(10/98)

Ziegler

D-92318, Neumarkt
Eberhard-Faber-Str.2
Nuernberg, Germany.
Tel. : 0049 9181 30483 / 42218
Fax : 0049 9181 30420
Mobile : 0171 961 7755
E-mail : info@ziegler-instruments.com