

ZIEGLER Master3100



ZIEGLER Master 3100 measures and displays basic electrical parameters like **AC Voltage, AC Current, Frequency, kVA, Neutral Current, Current Demand, kVA Demand**. All the measurements are true RMS up to 15th Harmonic for accurate measurement of non sinusoidal waveforms. The instrument can be configured and programmed at site for the following: PT Primary, CT Primary, CT Secondary 5A or 1A and 3 phase 3W or 4W. The instrument is available in the size 96 X 96 mm. Status of all parameters can be viewed through parameters screens on the 3 line, 4 digits Ultra High Brightness LED display.

Features

- DIN Quadratic Housing : Size 96 X 96 mm
- Measurement and display of up to 18 Electrical parameters
- Ultra Bright 3 line 4 digits LED display : Simultaneous display of 3 parameters (Digit height = 11 mm)
- True RMS measurement (up to 15th Harmonic)
- Fully programmable PT/CT ratios
- On site User Programmable CT Secondary : 5A <-> 1A
- On site User Programmable Connections : 3 phase 3W <-> 4W
- Compact Housing:
Low Back Depth on Panel
- Housing complies to: DIN43700
- Simple menu driven interface

Electrical Parameters

- 3 phase Voltages (L-L and L-N)
- 3 phase Currents
- Frequency
- System kVA
- Current Demand & Max Current Demand
- kVA Demand & Max kVA Demand
- Neutral Current

Applications

- DG set Manufacturers
- Distribution systems
- Control panels
- Building management
- Demand management

Operation

ZIEGLER Master 3100 is simple to operate and has high functionality. **ZIEGLER Master 3100** measures all the basic electrical parameters required for DG Set Manufacturers and applications which require Demand measurement. There are two buttons on the front panel for accessing the measured parameter and configuration screens. Using the “>> **NEXT**” button, it is possible to access the 18 electrical parameters to be viewed through the display screens. User can also scroll backward through display screens using “**ADJUST^^**” key. Display screens include measurement of three-phase voltages, currents (both the phase and system), Frequency, Ampere Demand & kVA Demand. The configuration screens are easily accessed by pressing both “**ADJUST^^**” and “>>**NEXT**” Keys simultaneously for 5 seconds. Now it is possible to configure **PT and CT ratios, 3phase 3Wire or 4 wire, demand integration time, reset demand readings. There is no need to specify the Secondary of CT ->5A or 1A and 3 Phase 3 Wire or 4 Wire while ordering the instrument as the instrument is programmable on site.**

To prevent unauthorized access to the product configuration settings, all set-up screens can be protected by an optional customer programmable password. Once configured, the status of each parameter can be viewed by using the “>>**NEXT**” / “**ADJUST^^**” key to scroll through each screen. Measurements are clearly displayed via a 3 line, 4 digits LED display.

ZIEGLER Master3100

Specifications:

Input	
Nominal Input Voltage	57.7V L-N to 277V L-N (100V L-L to 480V L-L)
Max Continuous Input Voltage	120% of Nominal Value
Max Short Duration Input Voltage	2 x Nominal value for 1 second, repeated 10 times at 10 second intervals
System PT Ratios (primary)	400kV **
Nominal Input Voltage Burden	< 0.2 VA approx. per phase
Nominal Input Current	5A <-> 1A (User Selectable)
System CT Primary Values	9999:5A or 9999:1A (max. 360MVA **)
Max Continuous Input Current	120% of Nominal Value
Max Short Duration Current Input	20 x nominal for 1 second, repeated 5 times at 5 minutes intervals
Nominal Input Current Burden	< 0.6 VA approx. per phase
Auxiliary	
Standard Nominal Supply Voltage	110V AC (-15% / + 20%) 230V AC (-15% / + 20%)
AC Supply Frequency Range	45 – 66 Hz
AC Supply Burden	≤ 3VA
Measuring Ranges	
Voltage	5 ... 120% of Nominal
Current	5 ... 120% of Nominal
Frequency	45.. 66Hz
Accuracy	
Voltage	±0.3% of range (50 ... 100% of range)
Current	±0.3% of range (10 ... 100% of range)
Neutral Current	± 4% of range (10 ... 100% of range)
Frequency	± 0.15% of mid frequency
Apparent Power (VA)	± 0.5% of range
Temperature Coefficient	0.08 %/°C typical for Voltage * 0.13 %/°C typical for other parameters *
Update Time	1.2 seconds
Enclosure	
Enclosure Style	DIN43700 [96mm x 96mm]
Compliant With	IEC 1010 / BSEN 61010-1
Material	Polycarbonate base and ABS Case
Terminals	Shrouded screw clamp
Dielectric Voltage	Withstand test 2.2kV RMS 50Hz for 1minute between all electrical circuits
Operating Temperature	0 to +55°C
Storage Temperature	-20 to +65°C
Relative Humidity	0.. 95% Relative Humidity
Warm-up Time	3 minutes (minimum)
Shock	15g in 3 planes
Vibration	10.. 55 Hz, 0.15mm amplitude
Enclosure	IP54 (front face)

** Maximum PT or CT ratios are limited so that the combination of Primary voltage and current do not exceed 360MVA at 120% of Rated input.

* Applicable for nominal Range of use 0... 50°C

ZIEGLER Master3100

<p>The ZIEGLER Master 3100 displays measured parameters on a 3 line 4 digit LED display. The displayed parameters are:</p> <ol style="list-style-type: none"> System Volts System Current Frequency Volts L1 – N (4Wire only) Volts L2 – N (4Wire only) Volts L3 – N (4Wire only) Volts L1 – L2 Volts L2 – L3 Volts L3 – L1 Current L1 Current L2 Current L3 Neutral Current (4Wire only) System Apparent Power Total system Current Demand Total System kVA Demand Maximum Total System Current Demand Maximum Total System kVA Demand 	<p>Programming ZIEGLER Master 3100 is easily programmed and parameters displayed using the two push buttons on the front panel. All configuration screens can be protected by an optional programmable password.</p>																					
	<table border="1"> <thead> <tr> <th>Parameter</th> <th>Range</th> </tr> </thead> <tbody> <tr> <td>Password</td> <td>4 digit 0000 – 9999</td> </tr> <tr> <td>Primary Current</td> <td>Max 9999:5A/1A **</td> </tr> <tr> <td>PT Primary</td> <td>400kV **</td> </tr> <tr> <td></td> <td>** maximum PT or CT ratios are limited so that the combination of primary voltage and current do not exceed 360MW at 120% of rated inputs</td> </tr> <tr> <td>Demand Integration Time</td> <td>8, 15, 20, 30 minutes</td> </tr> <tr> <td>Reset</td> <td>Ampere Demand, kVA Demand, Max Ampere Demand and Max. kVA Demand</td> </tr> </tbody> </table>		Parameter	Range	Password	4 digit 0000 – 9999	Primary Current	Max 9999:5A/1A **	PT Primary	400kV **		** maximum PT or CT ratios are limited so that the combination of primary voltage and current do not exceed 360MW at 120% of rated inputs	Demand Integration Time	8, 15, 20, 30 minutes	Reset	Ampere Demand, kVA Demand, Max Ampere Demand and Max. kVA Demand						
	Parameter	Range																				
	Password	4 digit 0000 – 9999																				
	Primary Current	Max 9999:5A/1A **																				
	PT Primary	400kV **																				
		** maximum PT or CT ratios are limited so that the combination of primary voltage and current do not exceed 360MW at 120% of rated inputs																				
	Demand Integration Time	8, 15, 20, 30 minutes																				
	Reset	Ampere Demand, kVA Demand, Max Ampere Demand and Max. kVA Demand																				
	<p>Ordering Codes</p> <table border="1"> <thead> <tr> <th>Ordering Code</th> <th>Product Configuration</th> </tr> </thead> <tbody> <tr> <td colspan="2">ZIEGLER Master 3100 – XXX – X</td> </tr> <tr> <td colspan="2">Input Voltage Suffix (XXX)</td> </tr> <tr> <td>110</td> <td>110V L-L (63.5V L-N)</td> </tr> <tr> <td>230</td> <td>230V L-L (132.79V L-N)</td> </tr> <tr> <td>415</td> <td>415V L-L (239.6V L-N)</td> </tr> <tr> <td>440</td> <td>440V L-L (254V L-N)</td> </tr> <tr> <td colspan="2">Auxiliary Voltage Suffix (X)</td> </tr> <tr> <td>L</td> <td>110 V AC (-15% / +20%)</td> </tr> <tr> <td>M</td> <td>230 V AC (-15% / +20%)</td> </tr> </tbody> </table>		Ordering Code	Product Configuration	ZIEGLER Master 3100 – XXX – X		Input Voltage Suffix (XXX)		110	110V L-L (63.5V L-N)	230	230V L-L (132.79V L-N)	415	415V L-L (239.6V L-N)	440	440V L-L (254V L-N)	Auxiliary Voltage Suffix (X)		L	110 V AC (-15% / +20%)	M	230 V AC (-15% / +20%)
	Ordering Code	Product Configuration																				
	ZIEGLER Master 3100 – XXX – X																					
	Input Voltage Suffix (XXX)																					
	110	110V L-L (63.5V L-N)																				
	230	230V L-L (132.79V L-N)																				
	415	415V L-L (239.6V L-N)																				
	440	440V L-L (254V L-N)																				
	Auxiliary Voltage Suffix (X)																					
	L	110 V AC (-15% / +20%)																				
	M	230 V AC (-15% / +20%)																				

Order Code Example:

ZIEGLER Master 3100 – 230– L : ZIEGLER Master 3100
3 Phase 3 wire/ 4 wire, 230V L-L nominal voltage, 5A/1A CT Input,
110V AC (-15% / +20%) Aux supply

Note: 5A/1A & 3Phase 3Wire / 4Wire are Programmable on site and hence no need to specify while ordering.

DISPLAYED PARAMETERS:

DISPLAYED Parameters	Three Phase 3 wire	Three Phase 4 wire
System Volts	ü	ü
System Current	ü	ü
Frequency	ü	ü
Volts L1 – N	ü	ü
Volts L2 – N	ü	ü
Volts L3 – N	ü	ü
Volts L1 – L2	ü	ü
Volts L2 – L3	ü	ü
Volts L3 – L1	ü	ü
Current L1	ü	ü
Current L2	ü	ü
Current L3	ü	ü
Neutral Current	ü	ü
System Apparent Power	ü	ü
Total system Current Demand	ü	ü
Total system kVA Demand	ü	ü
Maximum Total System Current Demand	ü	ü
Maximum Total System kVA Demand	ü	ü

ZIEGLER Master3100

Wiring

Input connections are made directly to shrouded screw clamp terminals. Numbering is clearly marked on the plastic moulding. Choice of cable should meet local regulations. Terminals for both current and voltage inputs will accept up to two 12 AWG diameter cables.

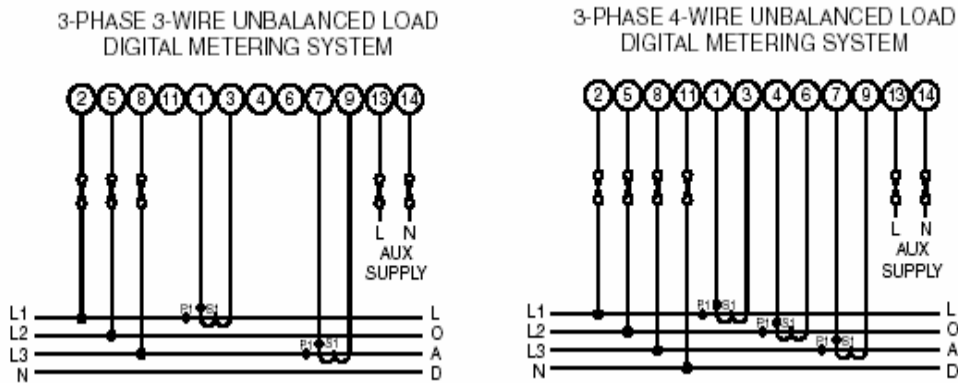

Auxiliary Supply

The **ZIEGLER Master 3100** should ideally be powered from a dedicated supply. However the device may be powered from the signal source, provided the source remains within the working range of the chosen auxiliary supply.

Fusing

It is recommended that all voltage lines be fitted with 1 amp HRC fuses.

Safety / Ground Connections

For safety reasons all CT secondary connections should be grounded in accordance with local regulations.

Dimensions

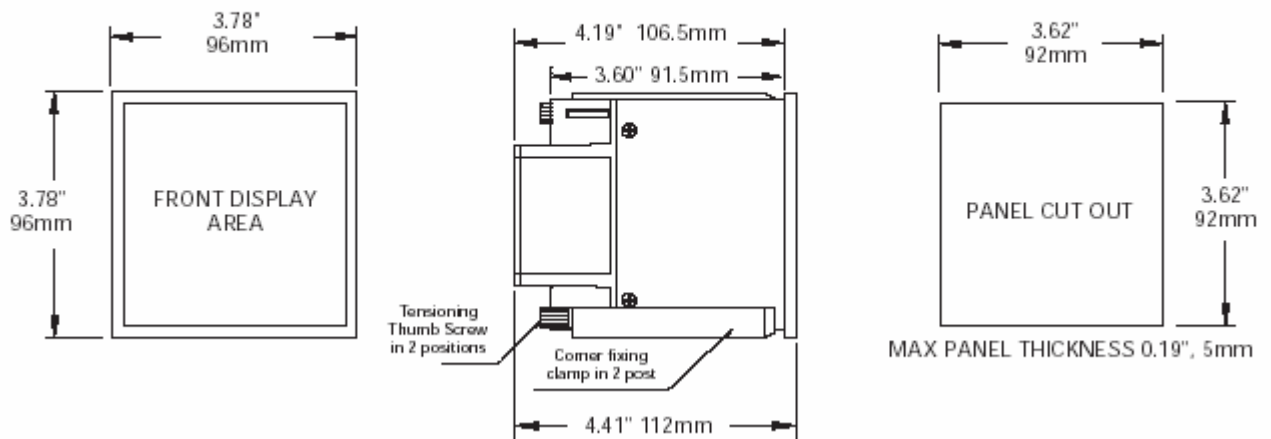

Subject to change without notice.

ZIEGLER INSTRUMENTS

D -92318, Neumarkt, Eberhard -Faber-Str.2, Nuernberg, Germany..

Tel. : 0049 918130483 / 42218

Fax. : 0049 918130420

E-mail : info@ziegler-instruments.com

Website : www.ziegler-instruments.com