

ZIEGLER MASTER 6400

Features :

- User selectable CT Secondary: 5A/1A
- User selectable 3 phase 3W or 4W
- Measurement and display of up to 29 power parameters
- True RMS measurement
- Fully programmable PT/CT ratios
- Simple menu driven interface
- Housing complies to:
EN60529, IEC529, BS5490,
DIN43700
- High brightness 3 line 4 digits LED display/ 3 parameter display
- Up to 2 programmable counters for Energy measurement (Import/Export)
- MODBUS (Rs485) RTU Protocol (2 Wire)

Monitors :

- Voltage: line to line & line to neutral
- Current, phase and neutral
- Frequency
- Power factor
- Power (active, apparent and reactive)
- Energy (reactive, active & apparent)
- Demand & Max Demand (Ampere, Active power, Apparent power)

Applications :

- **Power Distribution**
- **DG set Manufacturers**
- **Control panels**
- **Power Management**
- **Process Control**
- **Demand management**
- **Data logging**

MASTER 6100 measures and displays 29 major electrical and power quality parameters including Import/Export Energy and Maximum Demand measurement. All the measurements are true RMS up to 15th Harmonic for accurate measurement of non sinusoidal waveforms. Power and Power factor measurement is over 4 quadrants. The instrument can be programmed at site for PT Primary, CT Primary CT Secondary 5A/1A and 3 phase 3W or 4W. Status of all parameters can be viewed through 29 parameter screens on the 3 line, 4 digits high brightness LED display. Readings can be accessed via RS485 (MODBUS) RTU Protocol

Operation :

MASTER 6100 is simple to operate and has high functionality. MASTER 6100 measures all the electrical parameters required for power and energy measurements. There are two buttons on the front panel. For accessing the measured parameter and configuration screens. Using the ">> NEXT" button, it is possible to access the 29 major electrical and power quality parameters to be viewed through -- display screens. These include measurement of three-phase voltage and current, frequency, power factor measurement of both phase and system, current and voltage. The configuration screens are easily accessed by pressing both "ADJUST" and ">>NEXT" Keys simultaneously for 5 seconds. Now it is possible to set primary and secondary values for PT and CT, demand integration time, reset energy and demand readings.

To prevent unauthorized access to the product configuration settings, all set-up screens can be protected by an optional customer programmable password. Once configured, the status of each parameter can be viewed by using the ">>NEXT" button to scroll through each screen. Measurements are clearly displayed via a 3 line, 4 digits LED display.

System Input :

Designed for all low, medium and high voltage switchgear and distribution systems, the 6100 has customer programmable PT and CT ratio capability.

Direct connection up to 600V AC with 5A CT inputs or 1A CT inputs available. There is no need to specify the secondary of CT as it can be programmed to 5A or 1A on site.

ZIEGLER MASTER 6400

Specifications:

Input

Nominal Input Voltage :	57.7V L-N to 277V L-N (100V L-L to 480V L-L)
Max Continuous Input Voltage :	120% of Nominal Value
Max Short Duration Input Voltage :	2 x Nominal value for 1 second, repeated 10 times at 10 second intervals
System PT Ratios (primary) :	400kV **
Nominal Input Voltage Burden :	< 0.2 VA approx. per phase
Nominal Input Current :	5A <-> 1A (User Selectable)
System CT Primary Values :	9999:5A or 9999:1A (max. 360MVA **)
Max Continuous Input Current :	120% of Nominal Value
Max Short Duration Current Input :	20 x nominal for 1 second, repeated 5 times at 5 minutes intervals
Nominal Input Current Burden :	< 0.6 VA approx. per phase

Auxiliary

Standard Nominal Supply Voltage :	110 V AC \pm 20% or 230 V AC \pm 20% or 24V DC or 48 V DC
AC Supply Frequency Range :	45 – 66 Hz
AC Supply Burden/ DC Supply Burden :	5VA / 6W

Measuring Ranges

Voltage :	50 .. 120% of nominal (functional 5..120%)
Current :	5 .. 120% of nominal
Frequency :	45 .. 66Hz
Power Factor :	0.5 inductive – 1 – 0.8 capacitive
Energy :	7 digit resolution

Accuracy

Voltage :	\pm 0.5% of range (50 ... 100% of range)
Current :	\pm 0.5% of range (10 ... 100% of range)
Neutral Current :	\pm 4% of range (10 ... 100% of range)
Frequency :	0.2% of mid frequency
Power Factor :	1 % of Unity
Active power (W) :	\pm 0.5% of range
Reactive Power (VAr) :	\pm 0.5% of range
Apparent Power (VA) :	\pm 0.5% of range
Active energy (W.h) :	0.5% IEC1036 (PF 0.8-1-0.8)
Reactive energy (VArh) :	0.5% IEC1036 (PF 0.8-1-0.8)
kVAh :	0.5%
Temperature Coefficient :	0.08%/°C typical for Voltage * 0.013%/°C typical for other parameters *
Update Time :	1.2 Sec

Enclosure

Enclosure Style :	EN60529,IEC529,BS5490,DIN43700
Dielectric Voltage :	Withstand test 2.2kV RMS 50Hz for 1 minute between all electrical circuits\
Operating Temperature :	0 to +55°C
Storage Temperature :	-20 to +60°C
Relative Humidity :	0 .. 95% non condensing
Warm-up Time :	3 minutes
Shock :	15g in 3 planes
Vibration :	10 .. 55 Hz, 0.15mm amplitude
Enclosure Integrity :	IP54 (front face)

*Applicable for nominal Range of use 0... 50°C

** maximum PT or CT ratios are limited so that the combination of primary voltage and current do not exceed 360MW at 120% of rated input

Standards : Terms, Definitions & Test Methods As per IEC 60688: 1992
EMC Immunity: EN 61326

ZIEGLER MASTER 6400

<p>Programming</p> <p>MASTER 6100 is easily programmed and parameters displayed using the two push buttons on the front panel. All configuration screens can be protected by an optional programmable password.</p>		<p>The MASTER 6100 displays measured parameters on a 3 line 4 digit LED display. The displayed parameters are:</p> <ol style="list-style-type: none"> 1. System Volts 2. System Current 3. System kW 4. Volts L1 – N 5. Volts L2 – N 6. Volts L3 – N 7. Volts L1 – L2 8. Volts L2 – L3 9. Volts L3 – L1 10. Current L1 11. Current L2 12. Current L3 13. Neutral Current 14. Frequency 15. Power Factor 16. kVAr 17. kVA 18. Import kWh (7 digit resolution) 19. Export kWh (7 digit resolution) 20. Import kVArh (7 digit resolution) 21. Export kVArh (7 digit resolution) 22. Import kVAh (7 digit resolution) 23. Export kVAh (7 digit resolution) 24. kW Demand 25. Current Demand 26. kVA Demand 27. kW Maximum Demand 28. Current Demand maximum 29. kVA Maximum Demand 																									
<table border="1"> <thead> <tr> <th>Parameter</th> <th>Range</th> </tr> </thead> <tbody> <tr> <td>Password</td> <td>4 digit 0000 – 9999</td> </tr> <tr> <td>Primary Current</td> <td>Max 9999:5 (360MW max**)</td> </tr> <tr> <td>PT Primary</td> <td>400kV (360MW max**)</td> </tr> <tr> <td></td> <td>** maximum PT or CT ratios are limited so that the combination of primary voltage and current do not exceed 360MW at 120% of relevant inputs</td> </tr> <tr> <td>Demand Integration Time</td> <td>8, 15, 20, 30 minutes</td> </tr> <tr> <td>Reset</td> <td>Max demand & energy registers</td> </tr> </tbody> </table>	Parameter		Range	Password	4 digit 0000 – 9999	Primary Current	Max 9999:5 (360MW max**)	PT Primary	400kV (360MW max**)		** maximum PT or CT ratios are limited so that the combination of primary voltage and current do not exceed 360MW at 120% of relevant inputs	Demand Integration Time	8, 15, 20, 30 minutes	Reset	Max demand & energy registers												
Parameter	Range																										
Password	4 digit 0000 – 9999																										
Primary Current	Max 9999:5 (360MW max**)																										
PT Primary	400kV (360MW max**)																										
	** maximum PT or CT ratios are limited so that the combination of primary voltage and current do not exceed 360MW at 120% of relevant inputs																										
Demand Integration Time	8, 15, 20, 30 minutes																										
Reset	Max demand & energy registers																										
<p>Ordering Codes</p> <table border="1"> <thead> <tr> <th>Ordering Code</th> <th>Product Configuration</th> </tr> </thead> <tbody> <tr> <td colspan="2">MASTER 6100 - ***- *</td> </tr> <tr> <td colspan="2">Input Voltage Suffix ***</td> </tr> <tr> <td>110</td> <td>110V L-L (63.5V L-N)</td> </tr> <tr> <td>230</td> <td>230V L-L (133V L-N)</td> </tr> <tr> <td>415</td> <td>415V L-L (239.6V L-N)</td> </tr> <tr> <td>440</td> <td>440V L-L (254V L-N)</td> </tr> <tr> <td colspan="2">Auxiliary Voltage Suffix*</td> </tr> <tr> <td>L</td> <td>110 ± 20% AC</td> </tr> <tr> <td>M</td> <td>230 ± 20% AC</td> </tr> <tr> <td>N</td> <td>DC 48 V +/-10%</td> </tr> <tr> <td>O</td> <td>DC 24 V +/-10%</td> </tr> <tr> <td colspan="2">Communication Output: MODBUS (Rs485) RTU Protocol (2 Wire)</td> </tr> </tbody> </table> <p>Order Code Example:</p> <p>RISH Master 6100 – 230– L : <i>Master 6100</i> - 3 Phase 3 wire/ 4 wire, 230V L-L nominal voltage, 5A/1A CT Input, 110V AC (-15% / +20%) Aux supply</p> <p>Note: 5A/1A & 3Phase 3Wire / 4Wire are Programmable on site and hence no need to specify while ordering</p>		Ordering Code	Product Configuration	MASTER 6100 - ***- *		Input Voltage Suffix ***		110	110V L-L (63.5V L-N)	230	230V L-L (133V L-N)	415	415V L-L (239.6V L-N)	440	440V L-L (254V L-N)	Auxiliary Voltage Suffix*		L	110 ± 20% AC	M	230 ± 20% AC	N	DC 48 V +/-10%	O	DC 24 V +/-10%	Communication Output: MODBUS (Rs485) RTU Protocol (2 Wire)	
Ordering Code	Product Configuration																										
MASTER 6100 - ***- *																											
Input Voltage Suffix ***																											
110	110V L-L (63.5V L-N)																										
230	230V L-L (133V L-N)																										
415	415V L-L (239.6V L-N)																										
440	440V L-L (254V L-N)																										
Auxiliary Voltage Suffix*																											
L	110 ± 20% AC																										
M	230 ± 20% AC																										
N	DC 48 V +/-10%																										
O	DC 24 V +/-10%																										
Communication Output: MODBUS (Rs485) RTU Protocol (2 Wire)																											

ZIEGLER MASTER 6400

DISPLAYED PARAMETERS :

Power measurement	Three Phase 3 wire	Three Phase 4 wire
System Volts	✓	✓
System Current	✓	✓
System kW	✓	✓
Volts L1 – N	✗	✓
Volts L2 – N	✗	✓
Volts L3 – N	✗	✓
Volts L1 – L2	✓	✓
Volts L2 – L3	✓	✓
Volts L3 – L1	✓	✓
Current L1	✓	✓
Current L2	✓	✓
Current L3	✓	✓
Neutral Current	✗	✓
Frequency	✓	✓
Power Factor	✓	✓
kVAr	✓	✓
kVA	✓	✓
Import kWh (7 digit resolution)	✓	✓
Export kWh (7 digit resolution)	✓	✓
Import kVAh (7 digit resolution)	✓	✓
Export kVAh (7 digit resolution)	✓	✓
Import kVAh (7 digit resolution)	✓	✓
Export kVAh (7 digit resolution)	✓	✓
kW Demand	✓	✓
Current Demand	✓	✓
kVA Demand	✓	✓
kW Maximum Demand	✓	✓
Current Maximum Demand	✓	✓
kVA Maximum Demand	✓	✓

ZIEGLER MASTER 6400

Wiring :

Input connections are made directly to shrouded screw clamp terminals. Numbering is clearly marked on the plastic molding. Choice of cable should meet local regulations. Terminals for both current and voltage inputs will accept up to two 12 AWG diameter cables.

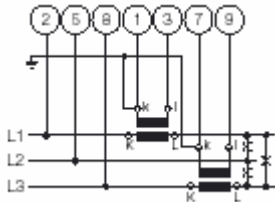

3 Phase 3 Wire :

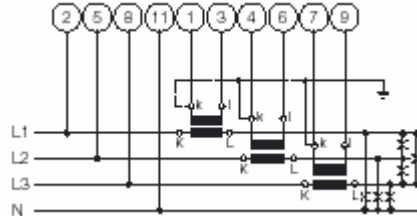

3Phase 4 Wire :

Auxiliary Supply :

Ideally the zIEGLER Master family should be powered from a dedicated supply, either from Ac auxiliary or DC auxiliary power supply.

Safety :

- 1) **Fusing** : 1 Amp. HRC fuses are recommended for all voltage lines .
- 2) **Ground Connections** : For safety reasons all CT secondary connections should be grounded in accordance with local regulations.

Dimensions :

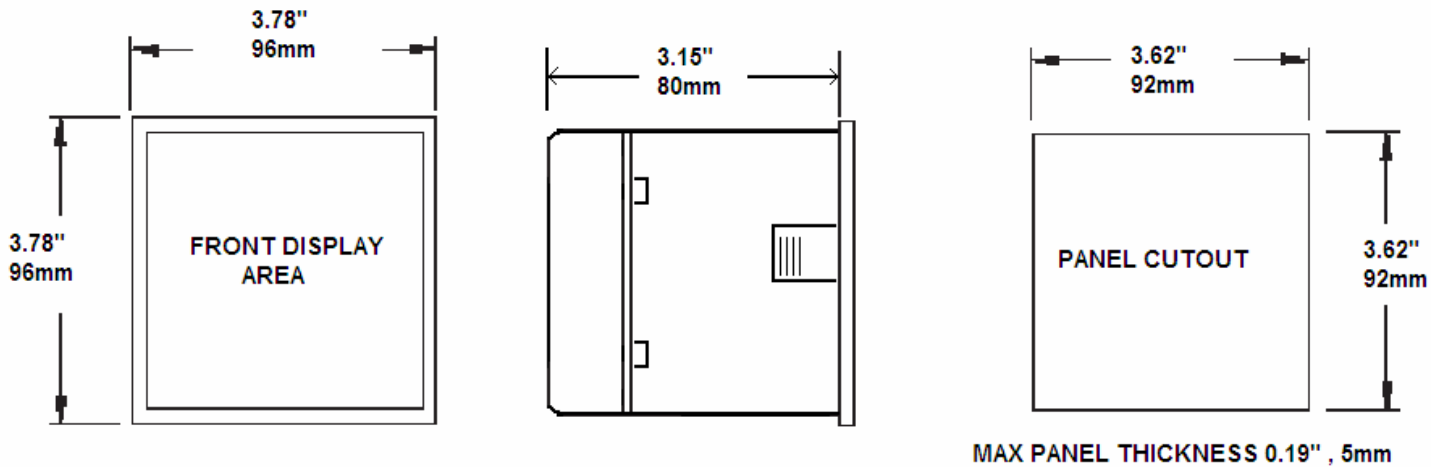

Subject to change without notice.

ZIEGLER INSTRUMENTS

D -92318,Neumarkt, Eberhard -Faber-Str.2, Nuernberg,Germany.

Tel. : 0049 918130483 / 42218

Fax. : 0049 918130420

E-mail : info@ziegler-instruments.com

Website : www.ziegler-instruments.com