

Ziegler Transducers

Series of Transducers for AC Current / AC Voltage

Ziegler Electrical Transducers

Ziegler products are thus the result of well proven technology and state of the art manufacturing facilities & expertise of Ziegler Instrument.

Ziegler Transducer are extremely reliable data sourcing elements for SCADA, PLC's, Energy Management System, and Building Management System (BMS) etc.

Ziegler Transducer are also useful for remote indications of electrical parameters, input to recorders, for feedback in control systems etc.

Current & Voltage Transducers series Ziegler IXX / VXX

Very wide range of product to meet the needs of varied applications.



Current : I11 - Average type, Self Powered. (Class 0.5)
I12 - Average type, Self Powered with dual range input (Class 0.5)
I21 - True RMS. (Class 0.5)
I22 - True RMS, (Class 0.2)

Voltage : V11 - Average type, Self Powered. (Class 0.5)
V21 - True RMS. (Class 0.5)
V22 - True RMS, (Class 0.2)

Ziegler IXX / VXX Series in E8 Housing

Unique Features :-

- State of the art products with SMT : Compact & reliable.
- Well proven technology from Gossen Metrawatt Camille Bauer, Germany / Switzerland.
- Meets requirements of International Standard IEC688 for accuracy
- Insulation level of 3.7kV/4kV.
- Impulse withstand voltage 5 kV.
- Higher load capacity : 750 Ohms at 20 mA.
- True RMS models (I21/V21).
- Self Powered models (I1X/V1X)
- Mounting : DIN rail or Panel mounting. Easy "onsite" conversion.
- Response time < 300 mS standard, < 50mS optional.
- Mounting position : Any
- Electrical isolation between all transducer connections.
- Terminal connection : Electricians delight. Even suitable for multistrand or solid wire connection. Large space for lopping of wires.

Ziegler Transducers

Series of Transducers for AC Current / AC Voltage

Unique Features :- (contd..)

- Housing : Polycarbonate, Flammability class V-0 acc to UL94, conforming to V0 grade of UL 94.
(Self extinguishing, non drip)
- Accuracy class 0.5 as per IEC 688, (I22 & V22 class 0.2.)
- Output short circuit & open circuit proof.
- Option of SMPS supply for wide range of ac/dc supply available.
- Option of bent transformation characteristic.
- Operating temperature - 10 to +55° C.
- Storage temperature - 40 to +70° C.

Symbols & Their Meaning

Symbols	Meaning
X	Measuring input / Input variable
X0	Start value of input voltage / current
X1	Elbow of input voltage
X2	Final value of input voltage / current
Y	Measuring output / Output variable
Y0	Start value of output variable
Y1	Elbow of output variable
Y2	Final value of output variable
H	Power supply
Hn	Rated value of power supply
T	Setting Time
Tn	Rated value of setting time
R _{ext} max	Max. output burden
Rn	Rated value of output burden

Ziegler Transducers

Series of Transducers for AC Current / AC Voltage

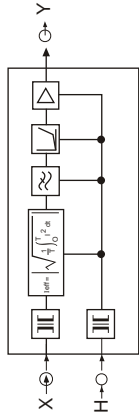
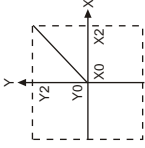
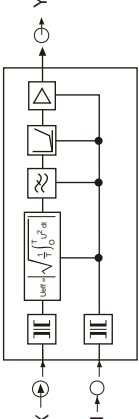
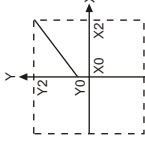
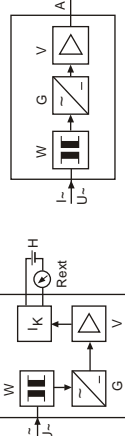
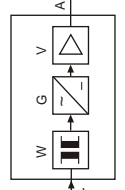
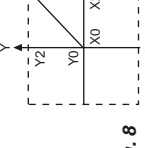
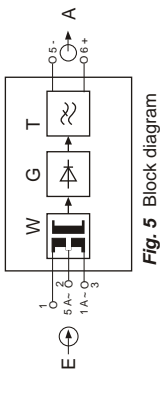
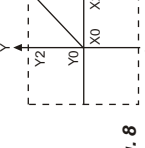
Layout and Mode of Operation	Block Diagram	Standard Transformation Characteristics
<p>I21 I22</p> <p>Input signal X is galvanically separated from the mains network using a transformer. The following mathematical expression is then formed using a RMS value Computer</p> $I_{eff.} = \sqrt{\frac{1}{T} \int_0^T i^2 dt}$ <p>Following filtration by means of an active filter, the transformation properties of the measuring transducer are determined in the characteristics circuit. The o/p amplifier transforms the measuring signal into an impressed o/p signal Y. The electronic components are supplied with voltage H from the mains supply unit.</p>	 <p>Fig. 1. Block diagram</p>	 <p>Fig. 6 Linear curve, characteristics (X0 = 0; Y0 = 0)</p>
<p>V21 V22</p> <p>Input signal X is galvanically separated from the mains network using a voltage transformer. The following mathematical expression is then formed using a RMS value computer</p> $V_{eff.} = \sqrt{\frac{1}{T} \int_0^T u^2 dt}$ <p>Following filtration by means of an active filter, the transformation properties of the measuring transducer are determined in the characteristics circuit. The o/p amplifier transforms the measuring signal into an impressed o/p signal Y. The electronic components are supplied with voltage H from the mains supply unit.</p>	 <p>Fig. 2 Block diagram</p>	 <p>Fig. 7 Linear curve, characteristics (X0 = 0; Y0 = 0)</p>
<p>I11 & V11</p> <p>The Transducer comprises a transformer W, a rectifier unit G and the amplifier V. The measured variable I/U AC is isolated from the electronics by the transformer W, and is rectified and smoothed in the rectifier unit G. The o/p amplifier V amplifies the resultant signal and converts it into the load-independent DC o/p signal A. The version with live-zero o/p has a 4mA constant current source to provide the zero setting. In the case of 2-wire connection the o/p increases from the zero setting of 4mA with an increase in measured value. The constant current source needs a supply voltage H between 12 and 30 V DC, which may be supplied typically from the main installation, the receiving equipments or a separate power pack.</p>	 <p>Fig. 3 Block diagram for transducer with live-zero output & 2-wire connection</p>  <p>Fig. 4 Block diagram for transducer with unipolar output.</p>	 <p>Fig. 8 Linear curve, characteristics (X0 = 0; Y0 = 0)</p>
<p>I12</p> <p>The Transducer comprises a transformer W, a rectifier unit G and a low-pass filter T. The measured variable is isolated from the electronics by the transformer W, and is rectified and smoothed in the rectifier unit G.</p>	 <p>Fig. 5 Block diagram</p>	 <p>Fig. 8 Linear curve, characteristics (X0 = 0; Y0 = 0)</p>

Ziegler Transducers

Series of Transducers for AC Current / AC Voltage

General and Measuring Input (other specification available on request)

Parameters		Ziegler I21	Ziegler I22	Ziegler V21	ZieglerV22	ZieglerI12	Ziegler I11 & V11		
General									
1	Measured Quantity	AC current Sine or distorted waveforms True RMS value measurement		AC voltage Sine or distorted waveforms True RMS value measurement		AC current or AC voltage sinusoidal arithmetical mean measured, calibration to rms with sine wave form (Average value)			
2	Measuring Principle	Logarithmic							
Measuring Input		Current		Voltage		Current and Voltage			
1	Nominal Frequency F_N	50,60 or 400 Hz		50,60 or 400 Hz		50 or 60 Hz			
2	Nominal input *	Current X2 : 1A < X2 < 7.5 A		Voltage X2 : 100 V ≤ X2 ≤ 500 V		Current I_N 1A or 5A Voltage V_N : 110/√3 / 110 / 150/ 240/ 415/ 440 V *			
3	Re-calibration of X2	Final value permanently set or final value can be adjusted in range 0.5.X2 ≤ X2		--		Range adjustable 0.9...1.1. I_N resp. V_N (± 10%) (Admissible alteration of full scale output, variable sensitivity, adjustable with potentiometer)			
4	Own Consumption	< 1 VA at X2		< 1 VA at X2		At nominal freq. 50 Hz : Full o/p value [mVA] 1 0.8 5 1.8 10 2.2 20 2.5 1.8			
5	Overload Capacity	Measured Qty	No of App	Duration of 1 Appl	Interval between 2 successive appln.	Measured Qty	No. of Appl	Duration of 1 Appl	Interval between 2 successive appln.
		2·X 2	--	Conti..	--	1.5 x I_N	Cont..	--	--
		10·X 2	5	3s	5 min	2 x I_N	10	10s	10 s.
		50·X 2 [®]	1	1s	1 h	10 x I_N	5	3s	5 min
		® X2=Final value, but ® max.250 A				1.5·X 2		1	1s

* Other input available on request

Ziegler Transducers

Series of Transducers for AC Current / AC Voltage

Measuring Output

Sr No.	Parameter	I21	I22	V21	V22	I12	I11 & V11	
1	Output variable Y	Load-independent DC current or DC voltage					Load - independent DC current I_A or DC voltage o/p V_A (not Superimposed)	
2	Load independent DC current output range	1 mA < $Y2$ < 20 mA					0...1/0...5/0...10 or 0...20 mA (4...20mA refer cl. for 2 wire output)	
3	O/p burden with DC current o/p signal	0 < R < 15V/Y2					$R_{ext} \text{ max. [K ohm]} = 15 V/I_{AN}$ [mA] I_{AN} = full o/p value	
4	DC voltage o/p range	1V < $Y2$ < 10 V					O/p V_A not superimposed : std range of V_A : 0...10V	
5	O/p burden with DC voltage o/p signal	$Y2/2\text{mA} < R < \infty$					Ext resistance > 200 k Ω /V	
6	Current limit under overload	$\leq 1.7 Y2$ with current o/p Approx. 20 mA with voltage o/p					$\leq 1.5 \times I_{AN}$ for current o/p Approx. 30 mA for voltage	
7	Voltage limit under $R_{ext} = \infty$	≤ 40 V with Current o/p $\leq 1.7 Y2$ with voltage o/p					<24 V	
8	Residual ripple in o/p signal	$\leq 5\%$ p.p at setting time 50 ms $\leq 0.5\%$ p.p at setting time 300 ms		$\leq 5\%$ p.p at setting time 50 ms and $C \leq 1$ $\leq 5\%$ p.p + $C 0.5\%$ at setting time 50 ms and $C > 1$ $\leq 5\%$ p.p at setting time 300 ms and $C \leq 1$ $\leq 2\%$ p.p at setting time 300 ms and $C > 1$			Current ripple $\leq 1\%$ p.p.	
9	Response time	≤ 300 ms standard, ≤ 50 ms optional					<300 ms	
10	Output Standard Ranges *	Current : 0-1mA/5mA/10mA/20mA/4-20mA Voltage : 0-10V					Current : 0...1/0...5/0...10 or 0...20 mA Voltage : 0-10V	

* Other ranges available on request.

Ziegler Transducers

Series of Transducers for AC Current / AC Voltage

Accuracy (IEC 688-1/ IS12784)

Parameters	I21	I22	V21	V22	I12	I11	V11
Reference Value	Output end value Y2						
Basic Accuracy (for std ranges)	Class 0.5	Class 0.2	Class 0.5	Class 0.2	Class 0.5	Class 0.5	Class 0.5

Reference Conditions

Parameters	I21	I22	V21	V22	I12	I11	V11	
Ambient Temp	23° C, ± 5 k							
Input Variable	Rated operating range							
Frequency	Fn ± 2%							
Distortion Factor	--							
External Resistance	Rn = 7.5 V/Y2 ± 1%		Rn = Y2/1 mA ± 1%		R ext Max - 1%			R ext Max to ∞
Curve shape	Sine - wave							
Shape Factor	1.1107							
Power Supply	Hn ± 1%		--		± 1 % for 24 V dc with 4-20 mA output			
Warm-up Time	< 5 min.							

Ziegler Transducers

Series of Transducers for AC Current / AC Voltage

Sr No.	Parameters	I21	V21	I22	V22	I12	I11 & V11	
1	Linearity Error	$< \pm 0.1\%$						$< \pm 0.3\%$
2	Frequency	----						----
3	Dependence on External resistance ΔR ext max.	$\pm 0.1\%$						$\pm 0.3\%$ (Fn $\pm 2\%$) $\pm 0.1\%$
Additional Errors *								
1.	Ambient Temp	Rated Operating range	Permitted effect factor of precision class	Rated Operating range	Permitted effect factor of precision class			
		+ 10°C...23°C...40°C + 0°C...23°C...55°C	1 2	Usage group II 0...23°C...45°C - 10°C...23°C...55°C	1 2	-25°C...+55°C $\pm 0.5\%$ 10K		
2.	Curve Shape of Input	Rectangle 1:1 Cut-in sine wave 90° (for V21)	1 2	Rectangle 1:1	1	Sine Waveform only		
		40...400 Hz > 400...1000 Hz	1 2	45..65 Hz --	1 --	45...55Hz $\pm 0.3\%$	45...200Hz $\pm 0.5\%$	
* not included in basic error								

Ziegler Transducers

Series of Transducers for AC Current / AC Voltage

Power Supply

Parameters	I21	I22	V21	V22	I12	I11	V11										
Version with AC Power packs standard voltage :-	<table border="1"> <thead> <tr> <th>Rated Value Hn</th> <th>Rated Operating Voltage</th> </tr> </thead> <tbody> <tr> <td>AC 24 V</td> <td>22...26V</td> </tr> <tr> <td>AC 110 V</td> <td>99...121V</td> </tr> <tr> <td>AC 230 V</td> <td>207 ...253V</td> </tr> <tr> <td>AC 400 V</td> <td>360...440V</td> </tr> </tbody> </table>							Rated Value Hn	Rated Operating Voltage	AC 24 V	22...26V	AC 110 V	99...121V	AC 230 V	207 ...253V	AC 400 V	360...440V
Rated Value Hn	Rated Operating Voltage																
AC 24 V	22...26V																
AC 110 V	99...121V																
AC 230 V	207 ...253V																
AC 400 V	360...440V																
Rated operating range of frequency :-	45...50...60...65 Hz																
Power consumption	AC < 4 VA at H=Hn DC < 4 w	AC < 3 VA at H=Hn DC < 3w	AC < 4 VA at H=Hn DC < 4 w	AC < 3 VA at H=Hn DC < 3w	--	--	--										
Version with AC / DC Power Packs (Dc & 45 -- 400 Hz)	<table border="1"> <thead> <tr> <th>Rated Voltage Un</th> <th>Permissible Variation</th> </tr> </thead> <tbody> <tr> <td>24...60 V DC/AC</td> <td>DC - 15...+33% AC ± 15%</td> </tr> <tr> <td>85...230 V DC/AC</td> <td></td> </tr> </tbody> </table>		Rated Voltage Un	Permissible Variation	24...60 V DC/AC	DC - 15...+33% AC ± 15%	85...230 V DC/AC		<table border="1"> <thead> <tr> <th>Power consumption</th> </tr> </thead> <tbody> <tr> <td>≤ 1.4 W resp. ≤ 2.7 VA</td> </tr> </tbody> </table>					Power consumption	≤ 1.4 W resp. ≤ 2.7 VA		
Rated Voltage Un	Permissible Variation																
24...60 V DC/AC	DC - 15...+33% AC ± 15%																
85...230 V DC/AC																	
Power consumption																	
≤ 1.4 W resp. ≤ 2.7 VA																	
DC Voltage Supply	--	--	--	--	--	12-30 V (only for 2-wire connection with output 4 ...20 mA)	--										

Ziegler Transducers

Series of Transducers for AC Current / AC Voltage

Installation Data

Sr No.	Parameters	I21	I22	V21	V22	I12	I11	V11
1	Mechanical Design	Housing 35 mm width (E8)						
2	Material of Housing	Glasfilled polycarbonate, flammability Class V-0 acc. to UL 94, self extinguishing, non-dripping.						
3	Mounting	DIN rail mounting (35 x 15 mm or 35 x 7.5 mm) acc. To EN 50 022 or Directly onto a wall or panel using to pull-out screw hole brackets (on site conversion possible)						
4	Mounting Position	Any						
5	Electrical Connection	Screw-type terminals with indirect wire pressure, for max. 2 x 2.5 mm ² or 1 x 6 mm ²						
6	Weight	Approx. 0.5 Kg						Approx. 0.4 Kg

Environmental Conditions

Sr No.	Parameters	I21	I22	V21	V22	I12	I11	V11
1	Climatic Rating	Climate Class 3Z acc. To VDI/VDE 3540						
2	Operating Temperature	-25 to +55 degree C		-10 to +55 degree C		-25 to +55 degree C		
3	Storage Temperature	-40 to +70 degree C						
4	Relative Humidity of Annual Mean	≤ 75%						
5	Permissible Vibration	2 g acc. To EN 60 068-2-6						
6	Shock	3 x 50 g 3 shocks each in 6 directions						

Ziegler Transducers

Series of Transducers for AC Current / AC Voltage

Regulations

Sr No.	Parameters	I21	I22	V21	V22	I12	I11 & V11
1	Safety Standards						
2	Housing Protection	Acc. To IEC 1010 IP 40 acc. To EN 60 529 Terminals IP 20					
3	Rated Insulation Voltage	Measuring input AC 300 V, Power supply AC 300 V, DC 230V Measuring output DC 40 V				--	--
4	Contamination Level	2				--	--
5	Over voltage Category	III				--	--
6	Protection Class	II				--	--
7	Safe Isolation	Acc. To IEC 1010 and DINVDE 106, part 101				--	--
8	Impulse withstand Voltage Acc to IEC 255-4 C1III:	5 KV 1.2/50 μ sec, 0.5 Ws Common-mode and differential mode between any terminals				--	5 KV 1.2/50 μ sec, 0.5 Ws Common-mode and differential mode between any terminals
9	Test Voltage	3.7 KV 50 Hz/1 min. between electrically isolated circuits. Measuring output versus housing 0.5 kV/50 Hz/1 min.				Measuring input versus measuring output 3.7 kV, 50Hz, 1 min. Measuring input versus housing 3.7 kV, 50Hz, 1 min measuring output versus housing 740V, 50 Hz, 1 min	4 kV/50 Hz/1 min
10	Product Performance	IEC 688, IS 12784					

Ziegler Transducers

Series of Transducers for AC Current / AC Voltage

Special Features (Optional) : Current & Voltage Transducer

- 1) 2 Wire output with 4-20 mA, for I11 & V11 with 12...30V DC AUX :

With 2 wire connection

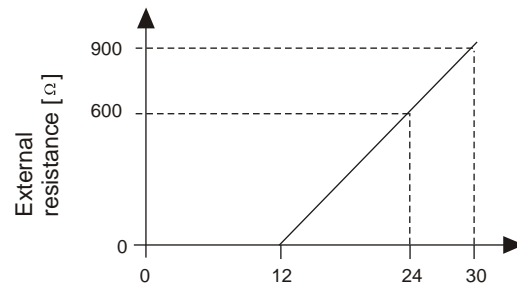

Fig . 9
Standard ranges of $I_A = 4...20$ mA
External resistance R_{ext} dependent
on power supply H (12...30 V DC)

$$R_{ext \text{ max. [k}\Omega]} = \frac{H[V] - 12V}{20mA}$$

- 2) Response Time <50 ms for I21 / I22 / V21 / V22
3) Special Transformation Characteristics :

A) Bent Characteristics.

Factor c (V21)

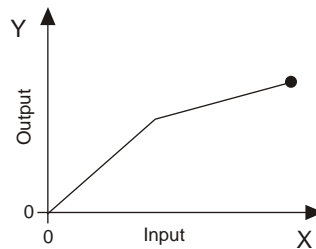

Fig. 10
Linear Curve = 1
BENT Curve
 $c = \frac{1}{1 - \frac{x1}{x2}}$ or $c = \frac{x2}{x1}$
(the larger value applies)

B) Suppressed Initial Range :

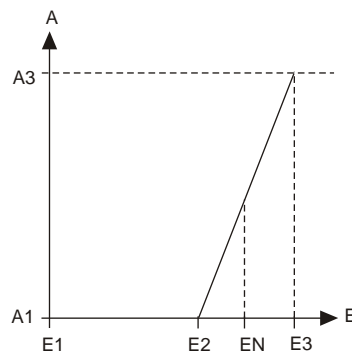

Fig. 11
Characteristic B
"Voltage magnifier in end range".
E1...E2 suppressed completely,
E2...E3 main measuring range magnified

Ziegler Transducers

Series of Transducers for AC Current / AC Voltage

C) Magnified Beginning or End of measuring range :

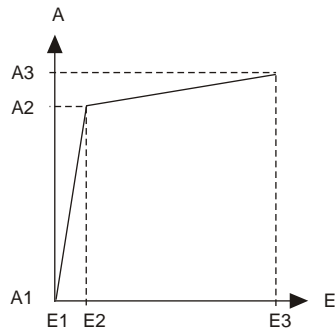

Fig. 12

Characteristic D "Main value magnification in initial range".
E1...E2 (main measuring range) magnified,
E2...E3 (secondary measuring range) suppressed
Input Magnification Of Initial range.

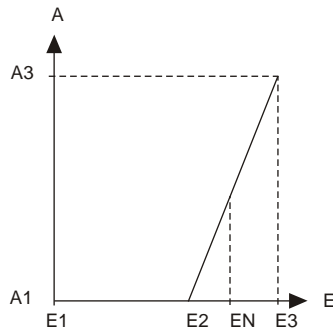

Fig. 13

Characteristic B "Current resp. Voltage magnifier in end range".
E1...E2 suppressed completely,
E2...E3 (main measuring range) magnified.
End Value Magnified.

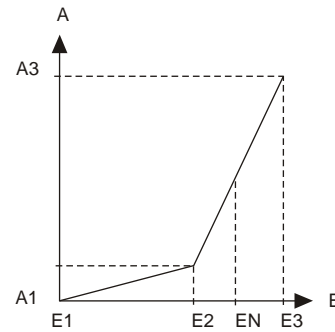

Fig. 14

Characteristic C "Main value magnification in end range".
E1...E2 (secondary measuring range) suppressed,
E3...E3 (main measuring range) magnified.
End Value Magnified.

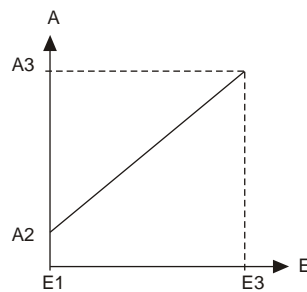

Fig. 15

Characteristic A "Standard and live zero."

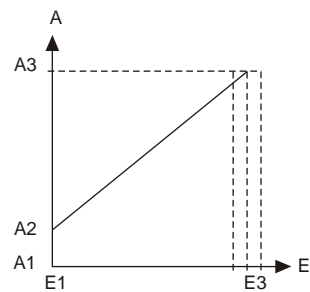

Fig. 16

Characteristic A "Standard" Variable sensitivity and live zero.

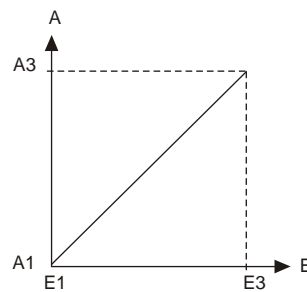

Fig. 17

Characteristic A "Standard"

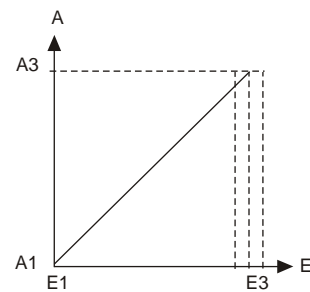

Fig. 18

Characteristic A "Standard and variable sensitivity." E3 adjustable by max. $\pm 5\%$ or $\pm 10\%$

4) Transformation Characteristics (V21) :

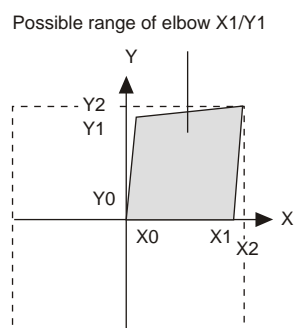

Fig. 19

Bent curve, characteristic
($X_0 = 0 \quad 0.05 X_2 < X_1 < 0.9 X_2$
 $Y_0 = 0 \quad Y_0 < Y_1 < 0.9 Y_2$).

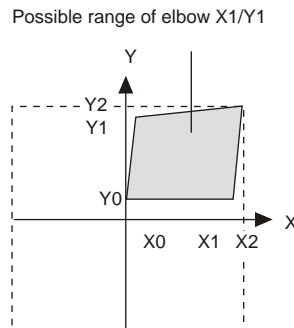

Fig. 20

Bent curve, characteristic
($X_0 = 0 \quad 0.05 X_2 < X_1 < 0.9 X_2$
 $Y_0 = 0.2 Y_2 \quad Y_0 < Y_1 < 0.9 Y_2$).

- 5) Any other input / output / power supply
- 6) Dual Chanel current Transducer
- 7) Dual output current Transducer.
- 8) Input Frequency (if other than 50 Hz)

Ziegler Transducers

Series of Transducers for AC Current / AC Voltage

Electrical Connection :

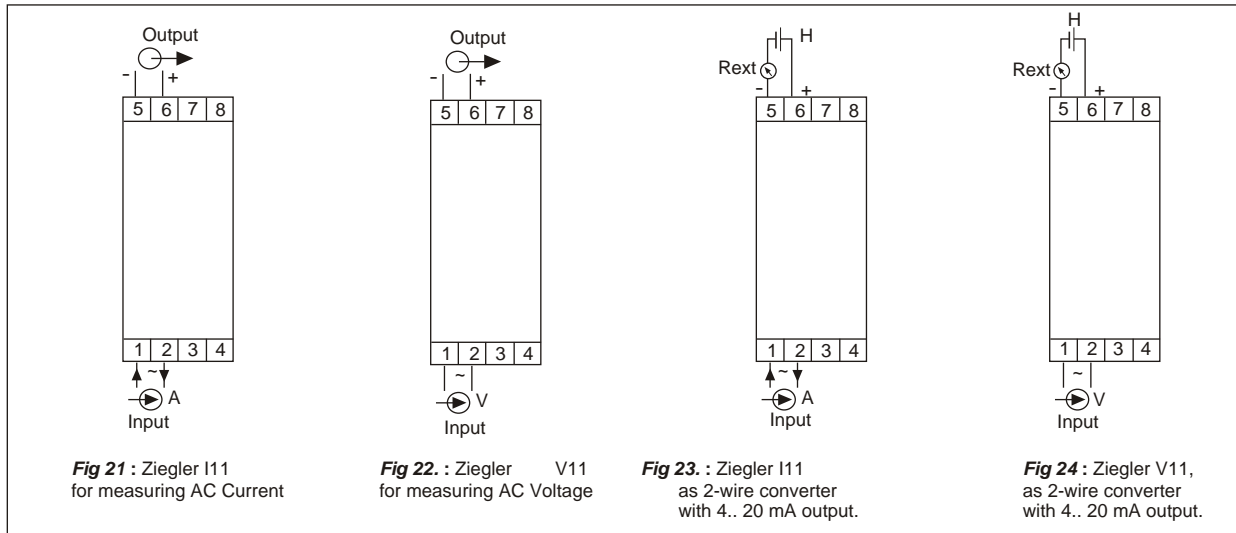

I11,V11

Connection	Connecting terminals
Measuring input E \rightarrow 1A~	1 and 3
Measuring input E \rightarrow 5A~	1 and 2
Measuring output A \rightarrow	5 - and 6 +

I12

Connection	Terminals
Measuring input \rightarrow	~ 1 ~ 3
Measuring Output \rightarrow	+ 13 - 14
Power supply \rightarrow	~,+ 21 ~, - 22

I21 / I22

Connection	Terminals
Measuring input \rightarrow	~ 2 ~ 5
Measuring Output \rightarrow	+ 13 - 14
Power supply \rightarrow	~,+ 21 ~, - 22

V21 / V22

Dimensional Drawing :

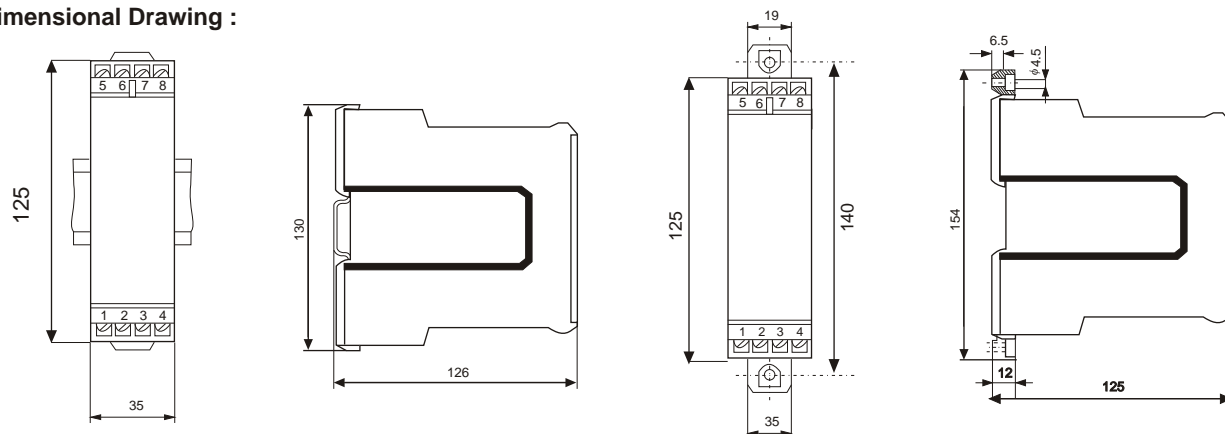

Fig 25. : Transducer in housing E8 clipped onto a top-hat rail (35 x 15 mm or 35 x 7.5 mm acc. to EN 50 022).

Fig 26. : Transducer in housing E8 with the screw hole brackets pulled out for wall mounting.

Ziegler Transducers

Series of Transducers for AC Current / AC Voltage

Specification & Ordering Information for TRMS Model

Sr. No.	Features Selection	Current Transducer	Voltage Transducer
1	Measuring Transducer for AC current/Voltage (RMS value measurement) Accuracy Class 0.5 0.2	I21 <input type="checkbox"/> I22 <input type="checkbox"/>	V21 <input type="checkbox"/> V22 <input type="checkbox"/>
2	Frequency of Input Current Fn = 50 Hz Fn = 60 Hz Fn = 400 Hz	<input type="checkbox"/> <input type="checkbox"/> <input type="checkbox"/>	
3	Final Value of Input Current 0...1A ... 7.5 A	<input type="checkbox"/> Specify range	Not applicable
4	Final value of input voltage ** 0...110/√3... 500 V * * >300 V; phase-to-phase connection to a 3-phase supply only.	Not applicable	<input type="checkbox"/> Specify range
5	Final value of output signal ** 0...1mA, 5mA, 10mA, 20mA, 4...20mA 0...10V	<input type="checkbox"/> <input type="checkbox"/> Specify range	
6	Linear Characteristics Bent (if applicable) X0 = 0 0.05.X2 < X1 < 0.9·X2 Y0 = 0 Y0 < Y1 < 0.9·Y2 X0 = 0 0.05.X2 < X1 < 0.9·X2 Y0 = 0.2.Y2 Y0 < Y1 < 0.9·Y2	Not applicable Not applicable	<input type="checkbox"/> Specify value of X1 & Y1 <input type="checkbox"/> Specify value of X1 & Y1
7	Re-calibration of X2 Final value permanently set Final value can be adjusted in range $0.5 \cdot X2 \leq X2$	<input type="checkbox"/> <input type="checkbox"/> Specify value	Not applicable
8	Response time 50ms 0.3s (standard)	<input type="checkbox"/> <input type="checkbox"/>	
9	Power Supply AC 22 V...26V AC 99V...121V AC 108V...132V AC 207V...253V AC 360V...440V * DC/AC 24V...60V DC/AC 85V...230V * > 300V; Phase -to-phase connection to a 3-phase supply only.	<input type="checkbox"/> <input type="checkbox"/> <input type="checkbox"/> <input type="checkbox"/> <input type="checkbox"/> <input type="checkbox"/> <input type="checkbox"/>	

Note :

Please tick ✓ in appropriate box

Also specify the ranges wherever necessary

** other specifications on request. (Contact to factory)

I12 model (Class 0.5)

For I12 model 1A/5A input is fixed only specify output signal 0...5 mA, 0...10mA, 0...20mA, 0...10V

Ziegler Transducers

Series of Transducers for AC Current / AC Voltage

Specification & Ordering Information for V_{11} / I_{11} model

Sr. No.	Features Selection	Current Transducer	Voltage Transducer
1)	Measuring Transducer for AC current/Voltage Accuracy class 0.5	I_{11} <input type="checkbox"/>	V_{11} <input type="checkbox"/>
2)	Measuring Range (Measuring Input Current) ** 0...1A, 0... 5A	<input type="checkbox"/> Specify range	Not applicable
	Measuring Range (Measuring Input Voltage) ** 0... 110 / $\sqrt{3}$ V, 0...500V	Not applicable	<input type="checkbox"/> Specify range
3)	Output Signal (measuring Output A)** 0...1mA, $R_{ext} \leq 15 \text{ k}\Omega$ 0...5 mA, $R_{ext} \leq 3 \text{ k}\Omega$ 0..10mA, $R_{ext} \leq 1.5 \text{ k}\Omega$ 0...20mA, $R_{ext} \leq 750 \Omega$ 4...20mA, 2 wire connection, R_{ext} dependant on power supply (12..30VDC) 0...10V, $R_{ext} \geq 200 \text{ k}\Omega / V$	<input type="checkbox"/> <input type="checkbox"/> <input type="checkbox"/> <input type="checkbox"/> <input type="checkbox"/> Specify Aux. supply volt DC <input type="checkbox"/>	
4)	Special Feature Without With (Specify separately)	<input type="checkbox"/> <input type="checkbox"/>	

Note :

Please tick in appropriate box

Also specify the ranges wherever necessary

** other specifications on request. (Contact to factory)

Ziegler Transducers

Series of Transducers for AC Current / AC Voltage

NOTES

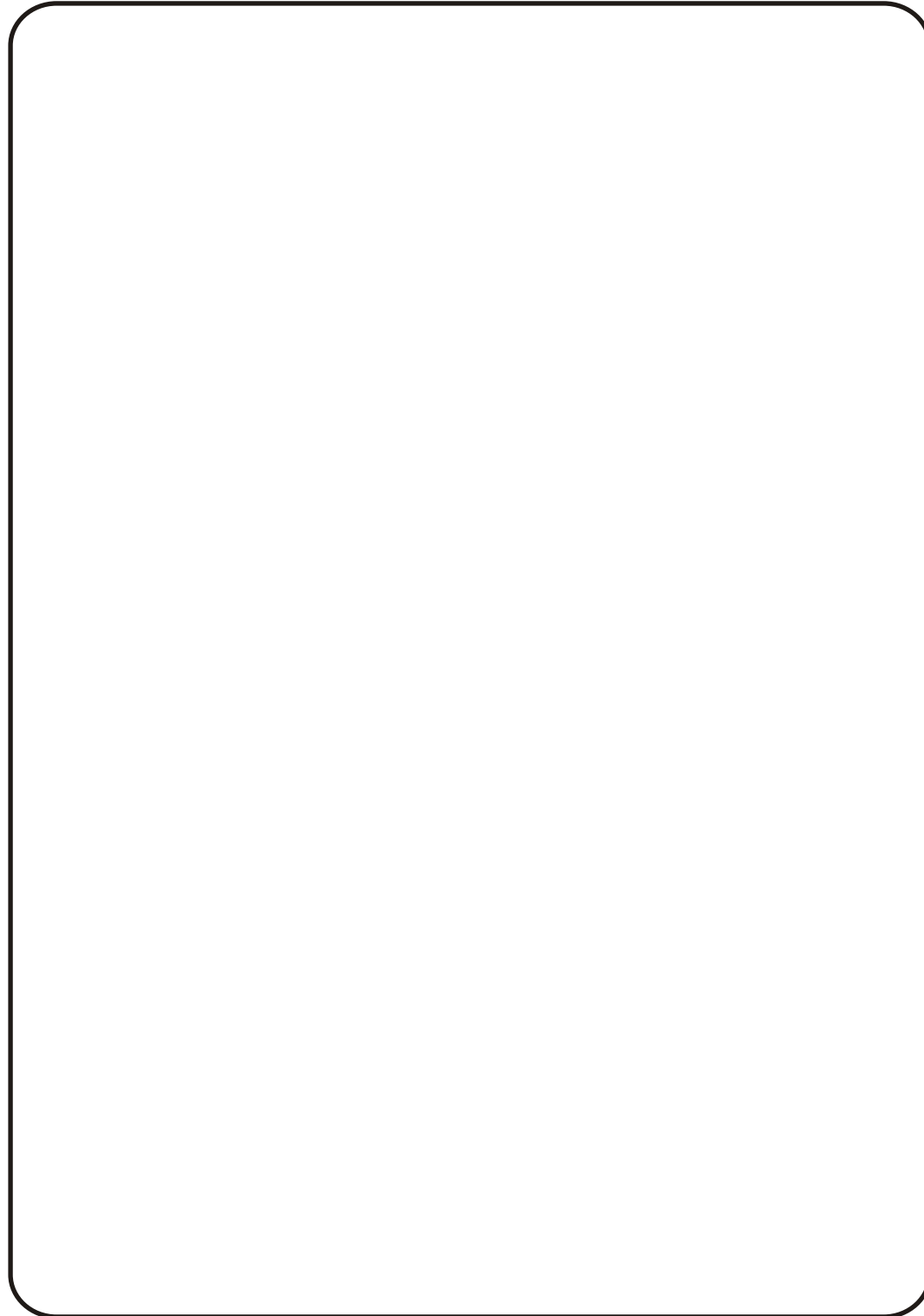

Ziegler Instruments

D-92318, Neumarkt, Eberhard-Faber-Str.2, Nuernberg, Germany
Tel. : 0049 918130483 / 42218 Fax : 0049 918130420
email : info@ziegler-instruments.com
Website : www.ziegler-instruments.com