

Ziegler E15

TRANSDUCER FOR AC CURRENT OR AC VOLTAGE WITH DIFFERENT CHARACTERISTICS

The Ziegler E15 transducer (Fig. 1 and 2) is used where a sine-wave AC current or voltage is to be converted into a DC signal proportional to the measured value (load-independent current or voltage).

Depending on the version, part of the measuring range of interest may be amplified at the beginning or end (voltage magnifier). The section of no or minor interest is suppressed.

A live zero output signal is possible with all versions.

Features / Benefits

- Different characteristics / Choice of the most suitable version according to application
- Narrow housing, 35 mm / Saves space and therefore costs
- Provision for either snapping the transducer onto top-hat rails or securing it with screws to a wall or panel
- Manufactured in SMD technology / Compact and reliable
- The device fulfils the protection requirements of the EMC guidelines (89/336/EWG). The device bears the CE symbol for EMC
- Screw terminals suitable for multistrand or thick solid wires
- Electric isolation between input/output and power supply (4 kV) / Personnel protection assured

Technical data

General

Measured quantity: AC current or AC voltage sinusoidal
Arithmetical mean measured, calibration to rms with sine wave form

Measuring principle: Active rectifier

Measuring input E \rightarrow

Nominal frequency f_N ①: 50 or 60 Hz

Nominal input current I_N : 1 / 1.2 / 5 or 6 A
(measuring range end value)

② ④ ⑤

Nominal input voltage U_N : $100/\sqrt{3}$ / $110/\sqrt{3}$ / $120/\sqrt{3}$ / 100 / 110 / 116.66 / 120 / 125 / 133.33 / 150 / 250 / 400 or 500 V
(measuring range end value)

③ ④ ⑤

Own consumption: <0.2 VA at current transducer
<1 mA at voltage transducer

① to ⑤ see section "Special features"



Fig. 1. Ziegler E15 clipped onto a top-hat rail.



Fig. 2. Ziegler E15 screw hole mounting brackets pulled out

Response sensitivity: <0.05% of full range value

Overload capacity:

Measured quantity I_N, U_N	Number of applications	Duration of one application	Interval between two successive applications
$2 \times I_N$	contin.	—	—
$10 \times I_N$	5	15 s	5 min.
$40 \times I_N$	1	1 s	—
$1.5 \times U_N$	contin.	—	—
$2 \times U_N$	10	10 s	10 s
$4 \times U_N$	1	2 s	—

Measuring output A \oplus

Output variable: Load-independent DC voltage U_A or load-independent DC current I_A

Standard ranges of U_A : 0...10 / 1...5 V
 (6) (7) Load capacity 20 mA

External resistance

$$R_{\text{ext}} [\text{k}\Omega] > \frac{U_A [\text{V}]}{20 \text{ mA}}$$

Standard ranges of I_A : 0...1/0...5/0...10/0...20/4...20 mA
 (8) (9) Burden voltage 15 V

External resistance

$$R_{\text{ext max.}} [\text{k}\Omega] = \frac{15 \text{ V}}{I_{\text{AN}} [\text{mA}]}$$

I_{AN} = Full output value

Voltage limit under $R_{\text{ext}} =$: Approx. 40 V

Current limit under overload: Approx. $1.3 \times I_{\text{AN}}$ at current output
 Approx. 30 mA at voltage output

Span adjustment: Approx. $\pm 2\%$

Output current ripple (10) : 1% p.p.

Response time: <300 ms

Output characteristic

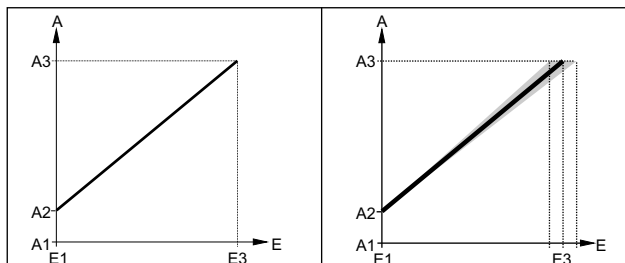
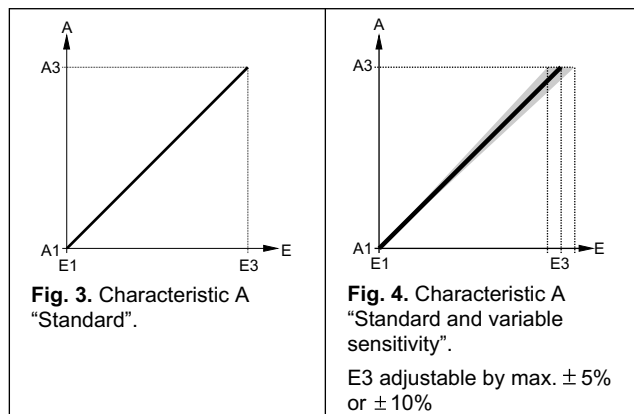

Fig. 5. Characteristic A "Standard and live zero".
 Condition: $A2 = 0.2 A3$

Fig. 6. Characteristic A "Standard, variable sensitivity and live zero".
 E3 adjustable by max. $\pm 5\%$ or $\pm 10\%$
 Condition: $A2 = 0.2 A3$

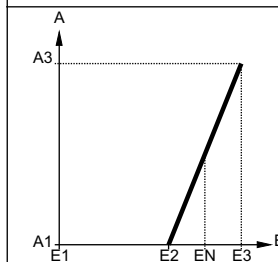

Fig. 7. Characteristic B "Current resp. voltage magnifier in end range".
 E1...E2 suppressed completely,
 E2...E3 (main measuring range) magnified
 Condition: $\frac{E3}{E2} = 1.22...1.66$

or, if power supply derived from voltage measuring input:
 $\frac{E3}{E2} = 1.22...1.35$

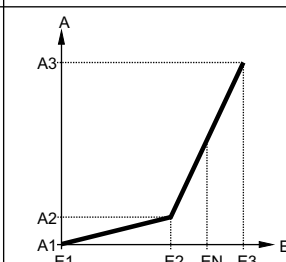

Fig. 8. Characteristic C "Main value magnification in end range".
 E1...E2 (secondary measuring range) suppressed,
 E2...E3 (main measuring range) magnified
 Conditions:
 $\frac{E3}{E2} = 1.22...1.66$

$A2 = (0.1 \text{ to } 0.25) A3$
 $\frac{A2 - A1}{A3 - A1} = 0.95 \frac{E2}{E3}$

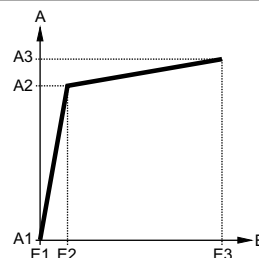

Fig. 9. Characteristic D "Main value magnification in initial range".

E1...E2 (main measuring range) magnified,
 E2...E3 (secondary measuring range) suppressed

Conditions:
 $\frac{E2}{E3} = 0.025^* \text{ to } 0.5$ and $\frac{A2 - A1}{A3 - A1} \geq 1.05 \frac{E2}{E3}$

$A2 = (0.4 \text{ to } 0.8) A3$

* between 0.025 and 0.05 reduced accuracy

(6) to (10) see section "Special features"

Accuracy (acc. to DIN/IEC 688—1)

Reference value:	Output span Exceptions: Characteristics B and C, Input end value
Basic accuracy:	Class 0.5
<i>Reference conditions</i>	
Ambient temperature:	23 °C, ± 5 K
Frequency:	$f_N \pm 2\%$
Distortion factor	<0.2%
Power supply:	$U_{HN} \pm 15\%$ (AC), $U_{HN} -15 / +33\%$ (DC)
Output burden	$0 \dots R_{ext} \text{ max.}$ at current output $R_{ext} \text{ min.}$... at voltage output
Output voltage:	0...15 V
Output current:	0...20 mA

Influence effects (maxima)

Included in basic error

Linearity error	±0.2%
Frequency influence $f_N \pm 5\%$	±0.05%
Dependence on external resistance ($R_{ext} \text{ max.}$)	±0.05%
Power supply influence $U_{HN} \pm 15\%$	±0.05%

Additional errors

Temperature influence (−25...+55 °C)	±0.5% / 10K
Frequency influence 45 — 65 Hz	±0.5%
Stray field influence 0.5 mT	±0.5%
Power supply influence $U_{HN} \pm 20\%$	±0.2%
Influence of common mode voltage 220 V, 50 Hz or 10 V, 1 MHz	±0.5%

Power supply

AC voltage: (11) (12)	24, 115, 120, 127, 230 or 240 V, ±15%, 50 / 60 Hz Power input approx. 5 VA
DC voltage:	24, 48, 60 or 110 V -15 / +33%, Power input approx. 5 W

Installation data

Mechanical design:	Carrying rail housing type E8 Dimensions see section “Dimensional drawing”
Material of housing:	Lexan 940 (polycarbonate), Flammability Class V-0 according to UL 94, self-extinguishing, non- dripping, free of halogen
Mounting:	For snapping onto top-hat rail (35 x 15 mm or 35 x 7.5 mm) acc. to EN 50 022 or directly onto a wall or panel using the pull-out screw hole brackets
Mounting position:	Any
Electrical connections:	Screw-type terminals with indirect wire pressure, for max. 2 x 2.5 mm ² or 1 x 6 mm
Weight:	Approx. 0.45 kg

Regulations

Impulse withstand voltage acc. to IEC 255-4, Cl. III:	5 kV, 1.2 / 50 s, 0.5 Ws Common-mode and differential- mode between any terminals
Electrical standards:	Acc. to DIN 57410
Housing protection:	IP 40 acc. to IEC 529 Terminals IP 20
Insulation group acc. to DIN 57 110 b:	A (instrument) C (terminals)
Test voltage:	4 kV / 50 Hz / 1 min. between electrically isolated circuits and versus housing

Environmental conditions

Climatic rating (13):	Climate class 3Z acc. to VDI/VDE 3540, but temperature continuously −25 to +55 °C. Relative humidity 75% annual mean (application class HVE acc. to DIN 40 040)
Storage temperature:	−40 to +70 °C

(11) to (13) see section “Special features”

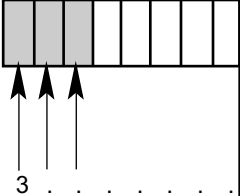

Table 1: Electromagnetic compatibility

The basic standards EN 50 081-2 and EN 50 082-2 were taken in account.

Conducted interference from the instrument	EN 55 011	Group 1, Class A	complies
HF radiation from complete instrument	EN 55 011	Group 1, Class A	complies
Electrostatic discharge on instrument	IEC 801-2	± 4 kV contact ± 8 kV air	without influence
HF field influence on instrument	IEC 801-3	27...500 MHz: 3 V/m, not modulated (ITU frequencies: 10 V/m)	influence < 2%
Electrical fast transient/Burst influence power, supply lines	IEC 801-4	± 2 kV, 5/50 ns, 5 kHz, asymmetrical, 2 min.	influence < 2%
Electrical fast transient/Burst influence, input and output lines	IEC 801-4	± 1 kV, 5/50 ns, 5 kHz, 2 min. capacitive coupled	without influence
Surge Immunity Requirements coupled on the power supply lines	IEC 801-5	symmetrical ± 1 kV asymmetrical ± 2 kV	without influence

The device fulfils the protection requirements of the EMC guidelines (89/336/EWG). **The device bears the CE symbol for EMC.**

Table 2: Specification and ordering information (see also Table 3: "Stock versions")

Order Code E-15 —			
Features, Selection	*SCODE	no-go	
1. Mechanical design 3) Carrying rail housing E8			
2. Output characteristic A) Characteristic A "Standard" see Fig. 3 "Standard and variable sensitivity", see Fig. 4 Note feature 9 "Measuring range adjustable" line A or B "Standard and live-zero", see Fig. 5 Note feature 5 "Output signal" line 2, 9, E or Z "Standard, variable sensitivity and live-zero", see Fig. 6 Note feature 9 "Measuring range adjustable" line A or B and 5 "Output signal" line 2, 9, E or Z	G		. A
B) Characteristic B "Current resp. voltage magnifier in end range", see Fig. 7	A		. B
C) Characteristic C "Main value magnification in end range", see Fig. 8	AB		. C
D) Characteristic D "Main value magnification in initial range", see Fig. 9	AB		. D
The selection feature 2 "Output characteristic" and feature 4 "Measuring range" as well as feature 5 "Output signal" to be determined together. In the section "Output characteristic" conditions laid down in Figs. 3 to 9 should be noted			
3. Nominal frequency 1) 50 / 60 Hz 9) Non-standard [Hz] 			. . 1 9

① see section "Special features"

Order Code E-15 —		
Features, Selection	*SCODE	no-go
4. Measuring range (measuring input E)		
1) 0...1 A	C	A
2) 0...1.2 A	C	A
3) 0...5 A	C	A
4) 0...6 A	C	A
9) Non-standard [A] 0...0.01 to 0...10 ^②	C	
A) 0...100/√3 V	D	A
B) 0...110/√3 V	D	A
C) 0...120/√3 V	D	A
D) 0...100 V	D	A
E) 0...110 V	D	A
F) 0...116.66 V	D	A
G) 0...120 V	D	A
H) 0...125 V	D	A
J) 0...133.33 V	D	A
K) 0...150 V	D	A
L) 0...250 V	D	A
M) 0...400 V	D	A
N) 0...500 V	DF	A
Z) Non-standard [V] 0...10.00 to 0...750 ^③		
Lines 1 to 9 and A to Z: Measuring range for characteristics A, Figs. 3, 4, 5 and 6 Lines 9 and Z: Measuring range for characteristics B, C and D, Figs. 7, 8 and 9 Specify range (E1... E2... E3) e.g. with characteristic B 90... 110 V e.g. with characteristic C 0... 90... 120 V e.g. with characteristic D 0... 10... 100 V		
5. Output signal (measuring output A)		
1) 0...10 V, $R_{ext} \geq 500$		B
2) 1... 5 V, $R_{ext} \geq 250$	E	B
9) Non-standard [V] 0...1.00 to 0...15 ^⑥ 0.2...1 to 3...15 ^⑦		
Lines 1 and 9: Output signals for characteristics A, Figs. 3 and 4 and characteristic B, Fig. 7 Lines 2 and 9: Output signals for characteristics A, Figs. 5 and 6 Line 9: Output signals for characteristics C and D, Figs. 8 and 9 Specify range (A1... A2... A3) e.g. with characteristic C 0... 2... 20 mA e.g. with characteristic D 0... 16... 20 mA		

Insert code figure in the 1st field of the next page!									
1
2
3
4
9
A
B
C
D
E
F
G
H
J
K
L
M
N
Z
.	1
.	2
.	9

②, ③, ⑥ and ⑦ see section "Special features"

Continuation "5. Output signal" see next page!

Order Code E-15 —									
Features, Selection		*SCODE	no-go						
5. Output signal (measuring output A) (continuation)									
A)	0... 1 mA, R_{ext} 15 k		B						
B)	0... 5 mA, R_{ext} 3 k		B						
C)	0...10 mA, R_{ext} 1.5 k		B						
D)	0...20 mA, R_{ext} 750		B						
E)	4...20 mA, R_{ext} 750	E	B						
Z)	Non-standard [mA] <input type="text"/>								
	0...> 1.00 to 0...< 20 (8)								
	1...5 to < (4...20) (9)								
Lines A to D and Z: Output signals for characteristics A, Figs. 3 and 4 and characteristic B, Fig. 7									
Lines E and Z: Output signals for characteristic A, Figs. 5 and 6									
Line Z: Output signals for characteristics C and D, Figs. 8 and 9									
Specify range (A1... A2... A3)									
e.g. with characteristic C 0... 2... 20 mA									
e.g. with characteristic D 0... 16... 20 mA									
6. Power supply			BCEFG						
0)	Internal from voltage measuring input (11)								
1)	24 V, 50/60 Hz								
3)	115 V, 50/60 Hz								
4)	120 V, 50/60 Hz								
5)	127 V, 50/60 Hz								
7)	230 V, 50/60 Hz								
8)	240 V, 50/60 Hz								
9)	Non-standard 50/60 Hz [V] <input type="text"/>								
	> 24 to 380 (12)								
A)	24 V DC, —15...+33%								
B)	48 V DC, —15...+33%								
C)	60 V DC, —15...+33%								
D)	110 V DC, —15...+33%								
Line 0: For AC > 40 Hz and characteristic B only, Fig. 7									
7. Special features									
0)	Without	Y							
1)	With								
Without special features (line 0): Order code complete.									
With special feature (line 1): The features to be omitted must be marked hereafter with / (slant line) in the order code until reaching the required feature									
8. Smaller residual ripple in measuring output (10)			Y						
A)	0.5% p.p. instead of 1% p.p. Response time approx. 800 ms (for current signals only)								
9. Measuring range adjustable (4)									
A)	E3 by max. ±5%, characteristic A, Figs. 4 and 6	AY							
B)	E3 by max. ±10%, characteristic A, Figs. 4 and 6	AY							

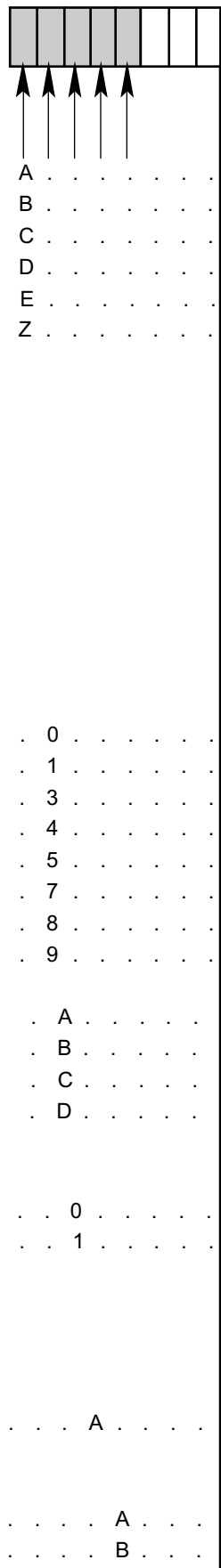

(4) and (8) to (12) see section "Special features"

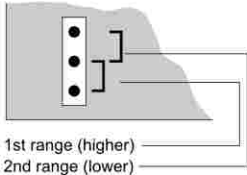
Nature of special features	
Two measuring ranges (for measuring input E)	
⑤	<p>Currents between 0...0.01 to 0...10 A Voltages between 0...10 to 0..750 V $I_1 : I_2$ or $U_1 : U_2 > 1.053$ to ≤ 2</p> <p><i>Restriction:</i> Possible only with characteristic A, Figs. 3, 4, 5 or 6</p>  <p>In each case the selected range is achieved by the change of a jumper</p>
Output signal A (measuring output A)	
⑥	<p><i>Load-independent DC voltage unipolar</i> Ranges between 0...1 and 0...15 V, besides the standard range 0...10 V</p>
⑦	<p><i>Live-zero</i> Ranges between 0.2...1 and 3...15 V, besides the standard range 1...5 V</p>
⑧	<p><i>Load-independent DC current unipolar</i> Ranges between 0...1 and 0...20 mA, besides the standard ranges 0...1/0...5/0...10 and 0...20 mA</p>
⑨	<p><i>Live-zero</i> Ranges between 1..5 and 4...20 mA, besides the standard range 4...20 mA</p>
Smaller residual ripple in measuring output	
⑩	<p>$\leq 0.5\%$ p.p. instead of $\leq 1\%$ p.p. <i>Restriction:</i> Response time approx. 800 ms instead of < 300 ms (for nominal frequency $f_N < 50$ Hz not possible)</p>
Power supply	
⑪	<p>without separate power supply connection Internal from voltage measuring input $(24 \text{ V} \leq EN \leq 380 \text{ V}, f$ <i>Restrictions:</i> Possible only with characteristic B With $U_N \geq 170 \text{ V}$: Impulse withstand voltage acc. to IEC 255-4, Cl. II: 1 kV, 1.2/50 μs, 0.5 Ws or overload capacity of the voltage input max. 680 V~, 2 s The additional power taken from the input voltage signal is approx. 5 VA</p>
⑫	<p>with AC voltage any voltage between 24 and 380 V, $\pm 15\%$, 50/60 Hz, power consumption approx. 5 VA besides the standard voltages: 24, 115, 120, 127, 230 or 240 V</p>
Improved climatic rating	
⑬	<p>Climate class 3Z acc. to VDI/VDE 3540, but temperature continuously -25 to $+55$ °C. Relative humidity $\leq 90\%$ annual mean (Application class HVR acc. to DIN 40 040)</p>

Electrical connections

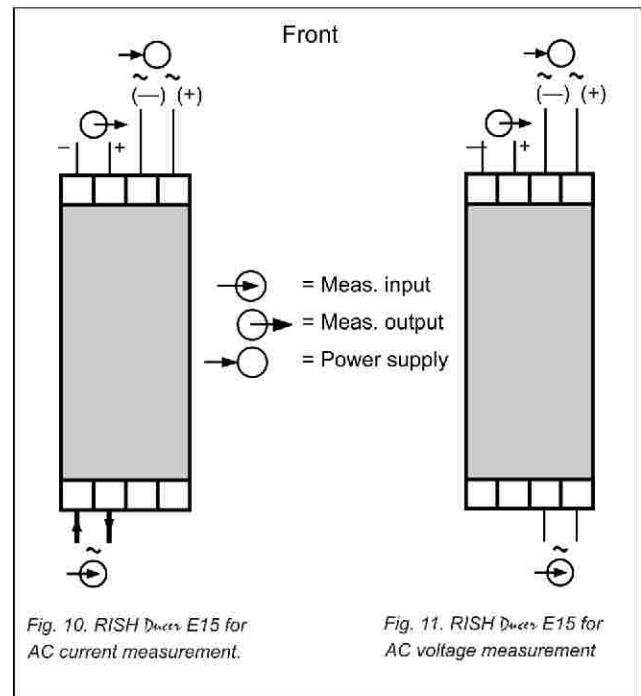

Dimensional drawings

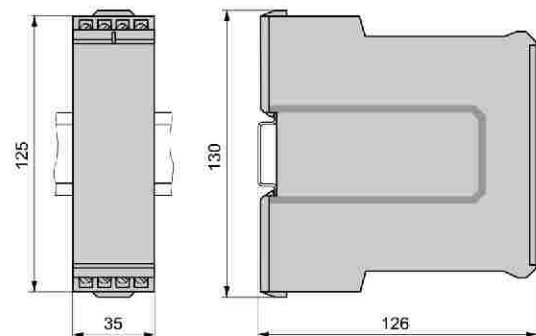

Fig. 12. Transducer clipped onto a top hat rail ($35 \cdot 15$ mm or $35 \cdot 7.5$ mm) acc. to EN 50 022.

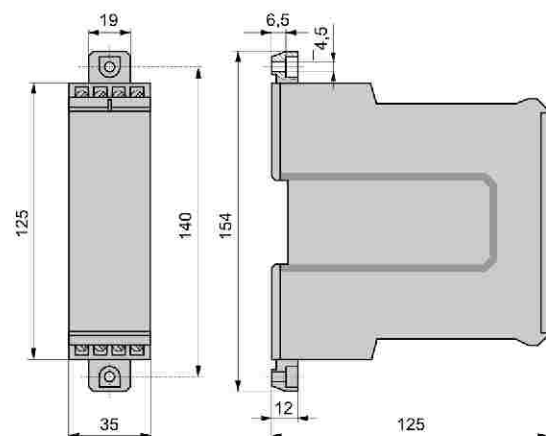

Fig. 13. Transducer with the screw hole brackets pulled out for wall mounting.